



HARDGOODS

WINTER COLLECTION 2017-18

HEAD[®]

THANK YOU LIMITS.

WHAT'S
YOUR
LIMIT?

Thank you for making me set goals.
For giving me something to strive for.
Without you Limits, there would be no challenge.
No tears.
No triumph.
Thanks to you, I grow and progress.
Forging new paths beyond the
boundaries you set.
You force me to understand
who I really am, by taunting me to
push myself harder.
Because you try to hold me back,
I cannot be stopped.
What's Your Limit?

WHAT'S
YOUR
LIMIT?

THE MAN WHO LOVED WHAT SKIING COULD BE.

For hundreds of years, ski technology barely changed. Sure, stronger woods made an appearance, camber came onto the scene, and tips and tails got wider, but that was about it. And then one day in 1947, an aeronautical engineer named Howard Head went skiing for the first time. And he was not impressed.

Howard knew there had to be a way to make skis lighter, faster, and more friendly. He set to work for three years, creating one prototype after another, and step by step, the HEAD ski came to life.

With its plywood core, aluminum sheets, plastic sidewalls, and a continuous steel edge, it was a revolution on the slopes. Suddenly anyone could ski and have fun at the same time.

And the rest, along with the competition, was history.





That's the problem with brilliant engineering: it only makes itself apparent when the ski disappears beneath you. It's the problem with incredible design: a boot can be so sublimely comfortable that you can totally focus on other things - like the finish line. And it's the burden of every athlete - the faster they go, the easier they make it look. At HEAD, we're inspired by those who push themselves, drive the sport, and create solutions. And if you ever get to visit our headquarters, you may find that we're inspired pretty much all the time - because we're surrounded by those people every day.

So we'd like to take a moment to say thanks to every staff member and all our athletes. Together, you're pushing the industry forward, and inspiring more and more people to put on skis and discover this beautiful sport. And every time we ask you What's your limit? The answer only opens another question,

What limit?.

BEHIND THE SCENES

IT'S EASY TO LOOK AT A SKI OR A BOOT AND FORGET ABOUT THE WORK THAT WENT INTO IT.

WHEN YOU'VE SEEN THE SPEED OF LIGHT

A hundredth of a second isn't the difference between first and second, it's the difference between winning and nothing at all. If you race, you understand. A centimeter is the grandest of canyons, and there's no such thing as fast enough. But thanks to our athletes and their insatiable demand for more speed, better speed, and faster speed, we're all going a lot quicker.

This is trickle-down technology at its finest. Though anything that fast could hardly be called a trickle.

WHEN YOU'VE SEEN
THE SPEED OF LIGHT
WHEN YOU LIVE ON THE EDGE
WHEN ADRENALIN
IS YOUR ONLY FUEL
WHEN YOU ARE THE ONLY
OPPONENT TO BEAT

WHAT'S YOUR LIMIT?

RACE combo



WHEN SLOWING DOWN IS A WASTE OF TIME

Winter can't come fast enough and never lasts long enough. Likewise, no run is fast enough or lasts long enough. But with snow on the ground and the right equipment at your feet (and everywhere else), there is bliss around each turn, and satisfaction at the end of every run.

And during those magical, powdery months, there is no limit to how hard we will push ourselves to make the most of every moment. Is it winter yet? How about now?

WHEN SLOWING DOWN
IS A WASTE OF TIME
WHEN YOU LIVE LIFE TO THE
FULLEST SPEED
WHEN YOU TURN
FEAR INTO TENACITY
WHEN YOU ARE USED
TO USING THE FAST LANE

WHAT'S YOUR LIMIT?

PERFORMANCE Combo



WHEN YOU ENJOY EVERY TERRAIN

Specialization is the mother of progress. Every season, specialized freeriders are going bigger and specialized racers are going faster on specialized equipment and specialized terrain. On the other hand, specialization kills freedom. The freedom to decide in the middle of the chair lift ride, whether you're going to race down the front or freeride down the back of the mountain.

The freedom to pull out of a multiple-G-turn and veer to the left into a virgin couloir. The freedom to go for one last full speed run on twilight ice as the sun sets behind the peaks you've ridden.

**WHEN YOU ENJOY
EVERY TERRAIN
WHEN THE IDEALS
ARE THE ONLY
THING YOU FOLLOW
WHEN YOU LOOK BEYOND
THE HORIZON AND
THEN GO TO SKI THERE
WHEN FOCUS CONQUERS FEAR**

WHAT'S YOUR LIMIT?

ALLRIDE combo



WHEN YOU GET OUT OF LINE TO FIND YOUR OWN

There is a mindset that fits into the crowd, follows the path, and stays in the box. And then there's the personality who dies for the challenge and lives for freedom.

Those who see skiing as a test of skill, and sometimes of fate. Or as the ultimate form of expression.

In man-made, in natural, and sometimes super-natural terrain. Freeriding and freestyle are brothers from different mothers. So is their attitude. And so is our equipment.

WHEN YOU GET OUT OF
LINE TO FIND YOUR OWN
WHEN YOU SKI
WHAT OTHERS GOOGLE
WHEN YOU'RE SLAVE
ONLY TO FREEDOM
WHEN TIME STOPS
WHILE YOU FLY

WHAT'S YOUR LIMIT?

FREESKI Combo

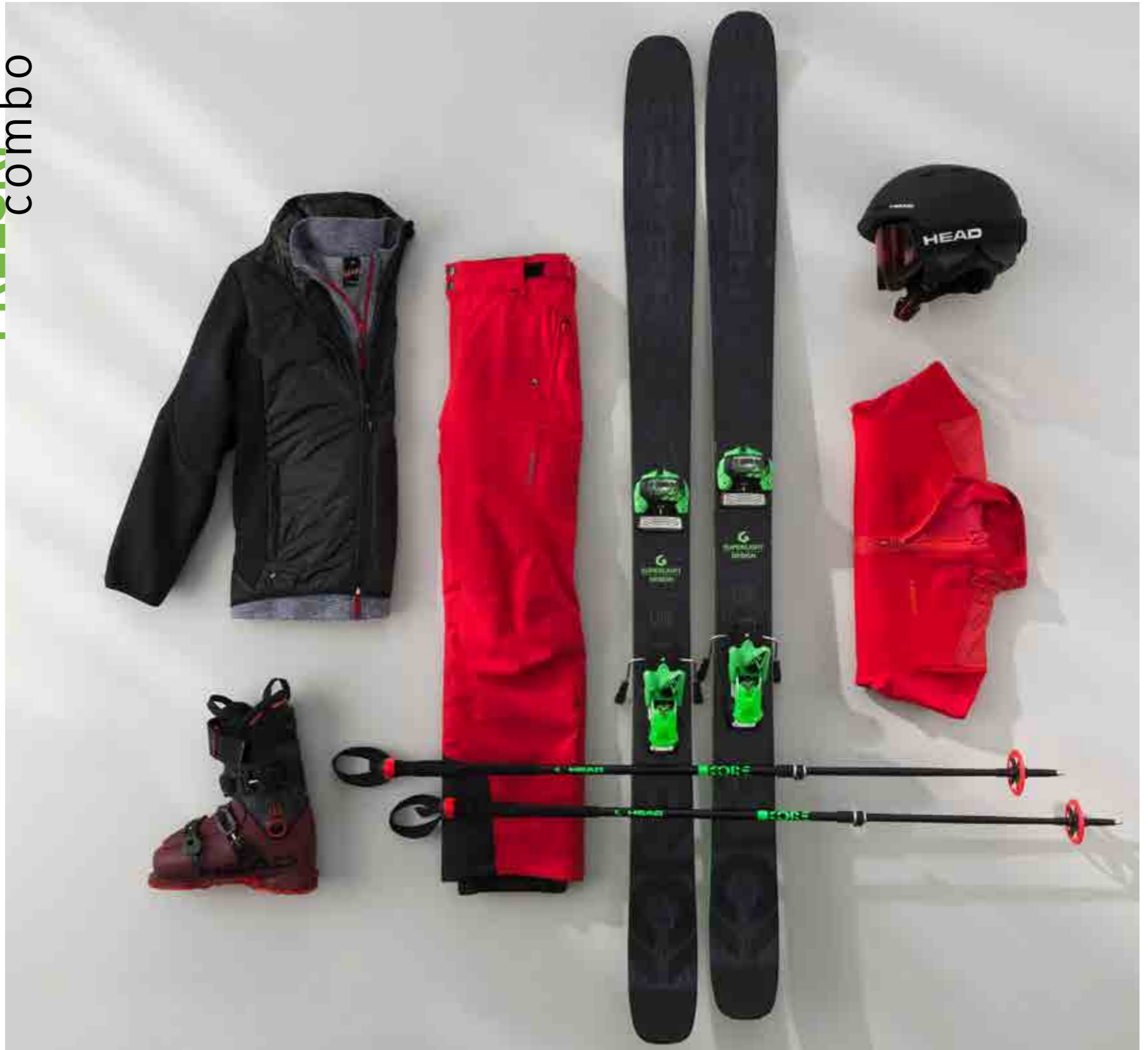

WHEN EVERY TURN BRINGS A SMILE OF JOY?

True love for skiing is unconditional.

It's not about flawlessness, prettiness, or prowess. It's about expressing yourself, not impressing others. Faith moves mountains, confidence skis them - from daybreak until nightfall.

Whatever your line and your limit:

The right equipment will turn bad weather into good karma, terrible hair days into big air days, and I-don't want-to-run-days into ounces of pure, striking joy.

WHEN EVERY TURN BRINGS
A SMILE OF JOY
WHEN YOU FIND
THE PERFECT LINE
WHEN YOUR GEAR FINALLY
MEETS YOUR ASPIRATIONS
WHEN YOU TURN BAD
WEATHER INTO GOOD KARMA

WHAT'S YOUR LIMIT?

WOMEN combo





WINTER COLLECTION 2017-18

SKIS



HEAD[®]



KORE

A STORY OF INNOVATION AND DESIGN, LIGHTNESS AND STRENGTH, AND A NEW HORIZON FOR FREERIDE. LEADING WITH A SIMPLE CONCEPT THAT LINKS TO THE SKI'S USP AND RELATES DIRECTLY BACK TO OUR REASON FOR FREERIDING...
PURE FRESHLY FALLEN POWDER.



LIGHTNESS

The revolutionary construction has been topped with a polyester fleece instead of a standard top-sheet. This topless Tech construction results in the lightest ski in its category. The triaxle weave of its carbon layer provides additional torsional rigidity for supreme responsiveness and solid edge hold.



FLOTATION

The Graphene fused tip and tail allows us to reduce and redistribute weight throughout the ski. The thinner profile enhances flotation in soft snow and maximizes maneuverability.



CONTROL

While the shock absorbing Koroyd gives the skier precise control in variable terrain, the ski provides strong torsional stiffness and great stability.

INNOVATION IS ABOUT DISCOVERING WHAT IS TRULY NECESSARY. IT IS NOT A PROCESS OF ADDITION, BUT SELECTION. TAKE AWAY THE BAGGAGE, THE EXTRA WEIGHT.
LEAVE ONLY THE PUREST.
LEAVE ONLY THE CORE.

#TOTHEKORE

KORE COLLECTION



KORE 93
"kind of chubby"

DIMENSIONS
133 - 93 - 115

RADIUS
16,4

LENGTH
153/162/171/180/189



KORE 105
"straight-up fat"

DIMENSIONS
135 - 105 - 125

RADIUS
17,8

LENGTH
171/180/189



KORE 117
"clinically obese"

DIMENSIONS
145 - 117 - 129

RADIUS
24,6

LENGTH
180/189

KORE is the most technically sophisticated freeride ski we've ever made. Here's why:

GRAPHENE

GRAPHENE is the strongest, lightest material known to man. We fuse it into the KORE's tip and tail to make it lighter and more responsive in deep snow.

KOROYD

KOROYD is a honeycomb shaped material at the heart of the KORE. It's super-light and incredibly elastic. It's strong and flexible and what makes the KORE special.

KARUBA

KARUBA wood core is what gives the ski its pop and personality. It's the perfect ratio of density and weight. The advantages of combining Karuba, Koroyd, and Graphene enhance the ski, making it light and balanced.



WORLD CUP REBELS i.SL

For those who never stop turning, and always turn quickly, this ski will take the fun-meter to 11

ARTICLE NUMBER

310207

FEATURES

KERS, Intelligence Technology
Graphene Worldcup Sandwich
Cap Construction
Race structured UHM C Base
Rebel Camber

DETAILS

LENGTHS	150/155/160/165/170
DIMENSIONS	124/68/108 @ Length 160
RADIUS	11,5 @ Length 160
PLATES	HEAD Race Plate EVO 14
BINDINGS	100656 Freeflex EVO 14 Brake 85 [A]

**WORLD CUP REBELS i.SPEED PRO**

The fastest retail ski on earth, equipped with the winning race plate. Fasten your seatbelt.

ARTICLE NUMBER

310227

FEATURES

KERS, Intelligence Technology
Graphene Worldcup Sandwich
Cap Construction
Race structured UHM C Base
Rebel Camber

DETAILS

LENGTHS	170/175/180/185
DIMENSIONS	119/68/99 @ Length 180
RADIUS	18,0 @ Length 180
PLATES	HEAD Race Plate WCR 14
BINDINGS	100655 Freeflex Evo 16 Brake 85 [A]





GRAPHENE



GRAPHENE



NEW

WORLD CUP REBELS i.SPEED

Buckle up and stay off all slow-marked slopes, because with the i Speed, you might have your ticket pulled

ARTICLE NUMBER

310247

FEATURES

KERS, Intelligence Technology
Graphene Worldcup Sandwich Cap Construction
Race Structured UHM C Base, Rebel Camber

DETAILS

LENGTHS 165/170/175/180/185
DIMENSIONS 119/68/99 @ Length 180
RADIUS 18,0 @ Length 180
PLATES Race Plate EVO 14
BINDINGS 100656 Freeflex Evo
14 Brake 85 [D]

WORLD CUP REBELS i.RACE

A combi race ski for those who know where FIS can stick their rules

ARTICLE NUMBER

310267

FEATURES

KERS, Intelligence Technology
Graphene Worldcup Sandwich Cap Construction
Race Structured UHM C Base, Rebel Camber

DETAILS

LENGTHS 160/165/170/175/180
DIMENSIONS 122/68/102 @ Length 170
RADIUS 14,4 @ Length 170
PLATES Race Plate EVO 14
BINDINGS 100656 Freeflex Evo
14 Brake 85 [D]

WC REBELS iSLR

Edge to edge and short turns have never been so much fun. Big smiles included

ARTICLE NUMBER

310367

FEATURES

Intelligence Technology, Worldcup sandwich construction, Race structured high speed UHM C base, Rebel Camber, Allride Base

DETAILS

LENGTHS 155/160/165/170
DIMENSIONS 122/66/107 @ Length 165
RADIUS 11,5 @ Length 165
PLATES Allride PR Base
BINDINGS 100717 PR 11 Brake 85 [G]

WC REBELS iGSR

A true race ski without those huge FIS radius. Easy race turns for the whole day.

ARTICLE NUMBER

310387

FEATURES

Intelligence Technology, Worldcup sandwich construction, Race structured high speed UHM C base, Rebel Camber, Allride Base

DETAILS

LENGTHS 160/165/170/175/180
DIMENSIONS 117/68/101 @ Length 170
RADIUS 14,4 @ Length 170
PLATES Allride PR Base
BINDINGS 100717 PR 11 Brake 85 [G]

WC REBELS i.SHAPE PRO

Want to ski like Ted Ligety? Can't squat 200kgs? No worries, the iShape Pro will make you feel like a champion.

ARTICLE NUMBER

310407

FEATURES

Intelligence Technology, ERA 3.0 Power Sidewall Ti Jacket, UHM C Base Rebel Camber, Allride Base

DETAILS

LENGTHS 149/156/163/170/177
DIMENSIONS 128/70/108 @ Length 170
RADIUS 13,4 @ Length 170
PLATES Allride PR Base
BINDINGS 100717 PR 11 Brake 85 [G]



GRAPHENE



GRAPHENE



GRAPHENE



GRAPHENE

SUPERSHAPE i.SPEED

Think fast? Talk fast? Ski fast? Wanna be faster?
Get on this front side master and speed up your life.

ARTICLE NUMBER

310327

FEATURES

KERS, ERA 3.0 S
Graphene Worldcup Sandwich Cap Construction
Race structured UHM C Base, Speed Rocker

DETAILS

LENGTHS 156/163/170/177/184
DIMENSIONS 124/68/104 @ Length 170
RADIUS 14,0 @ Length 170
PLATES MultiFlex PR Base
BINDINGS 100707 PRD 12 Brake 85 [F]

SUPERSHAPE i.MAGNUM

Like a fine champagne, there's only one size that counts –
the Magnum. Pop its cork and you'll fly like never before.

ARTICLE NUMBER

310307

FEATURES

KERS, ERA 3.0 S
Graphene Worldcup Sandwich Cap Construction
Race structured UHM C Base, Speed Rocker

DETAILS

LENGTHS 149/156/163/170/177
DIMENSIONS 131/72/110 @ Length 170
RADIUS 13,1 @ Length 170
PLATES MultiFlex PR Base
BINDINGS 100708 PRD 12 Brake 85 [F]

SUPERSHAPE i.RALLY

Stay on track and rally through every corner
with the ultimate side-stash-to-groomed ski.

ARTICLE NUMBER

310347

FEATURES

KERS, ERA 3.0 S
Graphene Worldcup Sandwich Cap Construction
Race structured UHM C Base, Speed Rocker

DETAILS

LENGTHS 156/163/170/177
DIMENSIONS 135/76/114 @ Length 170
RADIUS 13,7 @ Length 170
PLATES MultiFlex PR Base
BINDINGS 100709 PRD 12 Brake 85 [F]

SUPERSHAPE i.TITAN

Remember these Titans for slaying
the everywhere and the in-between.

ARTICLE NUMBER

310287

FEATURES

KERS, ERA 3.0 S
Graphene Worldcup Sandwich Cap Construction
Race structured UHM C Base, Speed Rocker

DETAILS

LENGTHS 156/163/170/177
DIMENSIONS 137/80/117 @ Length 170
RADIUS 14,1 @ Length 170
PLATES MultiFlex PR Base
BINDINGS 100710 PRD 12 Brake 85 [F]



P R E S T I G E

PRESTIGE

Skis destined for those with the most discerning taste for quality and performance. Where the bleeding edge of design and the peak of performance meet.

ARTICLE NUMBER

310606

FEATURES

ERA 3.0 S, Intelligence™ Chip Technology
 WC Sandwich Cap Construction
 Race Structured UHM C Base
 Speed Rocker

DETAILS

LENGTHS 156/163/170/177
 DIMENSIONS 135/76/114 @ Length 170
 RADIUS 13,7 @ Length 170
 PLATES TriFlex PR
 BINDINGS 100660 PRD 14 Brake 85 [F]



P R E M I U M

PREMIUM

Minimized to maximize what matters – high performance under cover of stealth beauty.

ARTICLE NUMBER

310626

FEATURES

ERA 3.0 S, Intelligence™ Chip Technology
 WC Sandwich Cap Construction
 Race Structured UHM C Base
 Speed Rocker

DETAILS

LENGTHS 156/163/170/177
 DIMENSIONS 124/68/104 @ Length 170
 RADIUS 14,0 @ Length 170
 PLATES TriFlex PR
 BINDINGS 100660 PRD 14 Brake 85 [F]



GRAPHENE



GRAPHENE



GRAPHENE



GRAPHENE

MONSTER 108

Step onto the Monster 108 and the steeps will seem flatter, the difficult easier, and the fun – way funner.

ARTICLE NUMBER

310807

FEATURES

ERA 3.0, Graphene WC Sandwich Cap Construction
Structured UHM C Base, Allride Rocker

DETAILS

LENGTHS 170/177/184/191
DIMENSIONS 142/108/127@ Length 177
RADIUS 23,5 @ Length 177
BINDINGS 114105 AAARENALIN 16 AT short w/o Brake [B]

MONSTER 98

The 98 is a Monster in any condition and is the ideal ski for those who dominate the front side and back side with equality.

ARTICLE NUMBER

310827

FEATURES

ERA 3.0, Graphene WC Sandwich Cap Construction
Structured UHM C Base, Allride Rocker

DETAILS

LENGTHS 163/170/177/184/191
DIMENSIONS 135/98/120 @ Length 177
RADIUS 21,3 @ Length 177
BINDINGS 114115 AAATTACK² 14 AT w/o Brake [A]

MONSTER 88

Stable and fast, yet nimble and fun. Fear not, this Monster will chew up and spit out any terrain that comes your way.

ARTICLE NUMBER

310847

FEATURES

ERA 3.0, Graphene WC Sandwich Cap Construction
Structured UHM C Base, Allride Rocker

DETAILS

LENGTHS 163/170/177/184
DIMENSIONS 133/88/114 @ Length 177
RADIUS 17,4 @ Length 177
BINDINGS 114122 AAATTACK² 13 GW 95 [A]

MONSTER 83

As the Jekyll and Hyde of the Monster series – the 83 is calm on the outside but ready to slay anything in its way. Corduroy beware – you will be trenched.

ARTICLE NUMBER

310867

FEATURES

ERA 3.0, Graphene WC Sandwich Cap Construction
Structured UHM C Base, Allride Rocker

DETAILS

LENGTHS 156/163/170/177/184
DIMENSIONS 125/83/110 @ Length 177
RADIUS 18,0 @ Length 177
BINDINGS 114129 AAATTACK² 13 GW 85 [A]



GRAPHENE



GRAPHENE



GRAPHENE



GRAPHENE



GRAPHENE

POWER INSTINCT Ti PRO

Skiers who long for freshly groomed snow as much as they do perfect powder have a new friend, the woo-and-metal-made Power Instinct.

ARTICLE NUMBER

310907

FEATURES

ERA 3.0
Graphene, WC Sandwich Cap Construction
Structured UHM C Base, Allride Rocker

DETAILS

LENGTHS 156/163/170/177
DIMENSIONS 124/82/109 @ Length 170
RADIUS 16,5 @ Length 170
PLATE Allride PR Base
BINDINGS 100713 PR 11 MBS Brake 85 [G]

RAW INSTINCT Ti PRO

Shaped for medium length turns and built with the perfect mix of metal and wood, the Raw is nimble, stable, and fun.

ARTICLE NUMBER

310947

FEATURES

ERA 3.0
Graphene, WC Sandwich Cap Construction
Structured UHM C Base, Allride Rocker

DETAILS

LENGTHS 149/156/163/170/177
DIMENSIONS 124/78/110 @ Length 170
RADIUS 14,7 @ Length 170
PLATE Allride PR Base
BINDINGS 100713 PR 11 MBS Brake 85 [G]

STRONG INSTINCT Ti

Finally, a mid-fat ski made ideal for mid-level skiers! Hard, soft, fast, or slow, find your inner Arnold on the Strong Instinct.

ARTICLE NUMBER

310967

FEATURES

ERA 3.0
Graphene, Power Sidewall Ti Jacket
Structured UHM C Base, Allride Rocker

DETAILS

LENGTHS 156/163/170/177
DIMENSIONS 130/83/115 @ Length 170
RADIUS 14,2 @ Length 170
PLATE Allride PR Base
BINDINGS 100713 PR 11 MBS Brake 85 [G]

SUPREME INSTINCT Ti

Curvy and carvy this ski is designed to make easy work of the piste and the bumps. Your search for Supreme fun ends here!

ARTICLE NUMBER

310987

FEATURES

ERA 3.0
Graphene, Power Sidewall Ti Jacket
Structured UHM C Base, Allride Rocker

DETAILS

LENGTHS 149/156/163/170
DIMENSIONS 127/74/110 @ Length 170
RADIUS 13,0 @ Length 170
PLATE Allride PR Base
BINDINGS 100713 PR 11 MBS Brake 85 [G]

NATURAL INSTINCT

It's true, some people are intimidated by skiing. Fear no more, this Instinct will make skiing feel easy, fun, and... Natural.

ARTICLE NUMBER

311007

FEATURES

ERA 3.0
Graphene, Power Sidewall Jacket
Structured UHM C Base, Allride Rocker

DETAILS

LENGTHS 149/156/163/170
DIMENSIONS 127/74/110 @ Length 170
RADIUS 13,0 @ Length 170
PLATE Allride PR Base
BINDINGS 100713 PR 11 MBS Brake 85 [G]



NEW

KORE 117

Wide like a sumo wrestler, but light like a ballerina, the Kore 117 defies stereotypes. It's strong and light, but stable and nimble. Go big, go light, go KORE.

ARTICLE NUMBER

311407

FEATURES

Graphene-KOROYD-Carbon Sandwich Cap Construction
 KARUBA Light Weight Wood Core
 Topless Tech, Split Sidewalls
 Structured diecut UHM C Base
 Tip-Tail Rocker

DETAILS

LENGTHS 180/189
 DIMENSIONS 145 / 117 / 129 @ Length 189
 RADIUS 24,6 @ Length 189
 BINDINGS 114113 AAATTACK² 16 GW w/o Brake [A]



KORE



NEW



KORE 105

For those who live on the edge, the KORE 105 will get you even further out there. Prepare to lead your posse with the perfect blend of lightweight and high performance. At a versatile 105mm, this is the perfect secret stash seeker.

ARTICLE NUMBER

311427

FEATURES

Graphene-KOROYD-Carbon Sandwich Cap Construction
 KARUBA Light Weight Wood Core
 Topless Tech, Split Sidewalls
 Structured diecut UHM C Base
 Tip-Tail Rocker

DETAILS

LENGTHS 171/180/189
 DIMENSIONS 135/105/125 @ Length 180
 RADIUS 17,8 @ Length 180
 BINDINGS 114113 AAATTACK² 16 GW w/o Brake [A]



NEW



KORE 93

Sometimes it's deep. Sometimes it's tracked. Sometimes it's bumped. Lots of times it's groomed. If this is when and where you ski, then the 93 is for thee. Any condition, any-time. #TOTHEKORE

ARTICLE NUMBER

311447

FEATURES

Graphene-KOROYD-Carbon Sandwich Cap Construction
 KARUBA Light Weight Wood Core
 Topless Tech, Split Sidewalls
 Structured diecut UHM C Base
 Tip-Tail Rocker

DETAILS

LENGTHS 153/162/171/180/189
 DIMENSIONS 133/93/115 @ Length 180
 RADIUS 16,4 @ Length 180
 BINDINGS 114126 AAATTACK² 13 GW w/o Brake 95 [A]

ALPINE WALKER SET

EXPLORE THE NATURE WITH THIS UNIQUE TOOL. ALL IN ONE, ONE FOR ALL.

THE ALPINE WALKER

The Alpine Walker is a ready to use ski package, which opens a completely new approach to the snow. The whole package can easily fit in the back of the car and it makes skiing up fun and skiing down a breeze. Whether you are alone or with all the family just take the Alpine Walker and start your skiing adventure.



ARTICLE NUMBER
310797 Complete Set which includes skis, bindings, poles, bag and skins

POLES
Two-part Telescope pole, 7075 Aluminum, Twist Lock, Bicomponent Grip, Diameter 16/14, 110-140 adjustable

SKI
Wood Core Cap Construction Nano Tech Surface

LENGTHS	130
DIMENSIONS	124/80/106 @ Length 130
RADIUS	10 @ Length 130
BINDINGS	AAAmbition 10 AT Brake 85 [C]

ALL COUNTRY SKINS

Composition:	65% Mohair and 35 % Nylon
--------------	---------------------------



CADDY

This Caddy will carry you over the top, above the lip, and beyond the wall. Parks, pipes, and hits make this ski shine – the more the better!

ARTICLE NUMBER
311527

FEATURES
Sandwich Twintip Construction Highly transparent UHM Base, Tuffwalls ISS-Independent Suspension System PNP Rocker

DETAILS	
LENGTHS	171/176/181
DIMENSIONS	120/84/109 @ Length 176
RADIUS	19,0 @ Length 176
BINDINGS	114121 AAATTACK ² 13 GW Brake 85]

FRAMEWALL

The first roll cage ever built with a ski in it, the Frame Wall is built tough for the rough and rowdy.

ARTICLE NUMBER
311507

FEATURES
Framewall, Sandwich Twintip Construction Diecut UHM C Base ISS – Independent Suspension System PNP Rocker

DETAILS	
LENGTHS	161/171/176/181
DIMENSIONS	121/84/110 @ Length 181
RADIUS	20,2 @ Length 181
BINDINGS	114129 AAATTACK ² 13 GW Brake 85 [A]

THE SHOW

Show off on this light and strong cap-wrapped wood core game-changer. Progress can be bought.

ARTICLE NUMBER
311547

FEATURES
Sandwich Twintip Construction Highly transparent UHM Base PNP Rocker

DETAILS	
LENGTHS	154/163/172/181
DIMENSIONS	112/79/106 @ Length 172
RADIUS	19,1 @ Length 172
BINDINGS	114129 AAATTACK ² 13 GW Brake 85 [A]

24^{HR} JOY**GREAT JOY**

Technology has never felt this great! At 98 mm, this amazing all mountain ski breezes through powder and glides over groomers.

ARTICLE NUMBER

311647

FEATURES

LIBRA: Women's Camber, ERA 3.0, Super Light Weight Distribution
Graphene Superlite Sandwich Cap Construction
highly transparent UHM Base, Allride Rocker

DETAILS

LENGTHS	153/158/163/168/173
DIMENSIONS	141/98/124 @ Length 168
RADIUS	14,3 @ Length 168
BINDINGS	114137 AAATTACK ² 12 GW Brake 110 [A]

WILD JOY

Every woman has a wild side. Skiers embrace it. Be wild and find JOY around every bend, mogul, and tree on the brand new Wild JOY. At 90mm under foot, this ski is ideal for those who are wild about everything from powder to groomers.

ARTICLE NUMBER

311667

FEATURES

LIBRA: Women's Camber, ERA, 3.0, Super Light Weight Distribution
Graphene KORROYD Carbon Construction
highly transparent UHM Base, Allride Rocker

DETAILS

LENGTHS	153/158/163/173
DIMENSIONS	139/90/119 @ Length 168
RADIUS	14,4 @ Length 168
BINDINGS	114136 AAATTACK ² 12 GW Brake 95 [A]

24^{HR} JOY**TOTAL JOY**

Light, fun, and easy, the total JOY brings a new meaning to all mountain high performance. Never has such an easy-turner been so incredibly emboldening.

ARTICLE NUMBER

311627

FEATURES

LIBRA: Women's Camber, ERA, 3.0, Super Light Weight Distribution
Graphene KORROYD Carbon Construction
Structured UHM C Base, Allride Rocker

DETAILS

LENGTHS	148/153/158/163/168
DIMENSIONS	133/85/113 @ Length 163
RADIUS	13,6 @ Length 163
PLATES	SuperLiteRail
BINDINGS	100690 JOY 11 SLR Brake 90 [H]

SUPER JOY

High speed, high class, and high fashion rule the super JOY. Maybe it's the other way around, since the Super Joy rules the slopes. No matter – reJOYce.

ARTICLE NUMBER

311607

FEATURES

LIBRA: Women's Camber, ERA, 3.0, Super Light Weight Distribution
Graphene KORROYD Carbon Construction
Structured UHM C Base, Allride Rocker

DETAILS

LENGTHS	143/148/153/158/163/168
DIMENSIONS	128/75/108 @ Length 163
RADIUS	12,5 @ Length 163
PLATES	SuperLiteRail
BINDINGS	100691 JOY 11 SLR Brake 78 [H]

 Light done right.

HR 24 JOY



EPIC JOY SLR

Nomen est Omen. With this on-piste beauty you have a high-performance, lightweight machine under foot. This will be an all-time classic.

ARTICLE NUMBER

311677

FEATURES

LIBRA: Women's Camber, ERA, 3.0, Super Light Weight Distribution
Graphene KORoyD Carbon Construction
Structured UHM C Base, Allride Rocker

DETAILS

LENGTHS 148/153/158/163/168
DIMENSIONS 120/65/100 @ Length 163
RADIUS 11,9 @ Length 163
BINDINGS 100725 JOY 11 SLR
Brake 78 [H]



ABSOLUT JOY

Balance and control this absolute will bring a smile to any improving skier's face. Go ahead, try to not smile – you can't! Truly, it's absolut JOY.

ARTICLE NUMBER

311687

FEATURES

LIBRA: Women's Camber, ERA 3.0, Super Light Weight Distribution
Graphene Power Sidewall Jacket, Superlite Composite Core
Highly transparent UHM Base, Allride Rocker

DETAILS

LENGTHS 143/148/153/158/163/168
DIMENSIONS 129/79/109 @ Length 163
RADIUS 13,5 @ Length 163
BINDINGS 100695 JOY 9 AC SLR
Brake 90 [H]

PURE JOY

Skiing is at the heart of joy, and this ski ensures you get plenty of it. Always easy going and always in control, the pure JOY will bring a lifetime on the slopes.

ARTICLE NUMBER

311707

FEATURES

LIBRA: Women's Camber, ERA 3.0, Super Light Weight Distribution
Graphene Power Sidewall Jacket
Highly Transparent UHM Base, Allride Rocker

DETAILS

LENGTHS 143/148/153/158/163
DIMENSIONS 127/73/107 @ Length 158
RADIUS 10,9 @ Length 158
BINDINGS 100696 JOY 9 AC SLR
Brake 78 [H]



WC IRACE TEAM SW SLR II

This ain't no toy ski. With a full wood core and sidewalls, young speedsters will be stable and quick as they race all over the mountain.

ARTICLE NUMBER

314147

FEATURES

Intelligence Technology
 Graphene WC Sandwich Construction
 UHM C Base, Structured Surface
 also available without SLR II ART.Nr: 314157

DETAILS

LENGTHS 100/110/120/130/140/150/160
 DIMENSIONS 111/67/95 @ Length 140
 RADIUS 10,8 @ Length 140
 PLATES SLR II Base
 BINDINGS 100678 SLR 7.5 AC Brake 78 [H]



SUPERSHAPE SLR II

Start them early, and start them often. With a high quality wood core, kids will learn faster and ski longer than ever before.

ARTICLE NUMBER

314187

FEATURES

Power Sidewall Jacket
 ERA 2.0, Structured Surface
 UHM C Base

DETAILS

LENGTHS 120/130/140/150/160
 DIMENSIONS 123/70/101 @ Length 140
 RADIUS 9,7 @ Length 140
 PLATES SLR II Base
 BINDINGS 100678 SLR 7.5 AC Brake 78 [H]



SUPERSHAPE TEAM SLR II

Start them early, and start them often. With a high quality sidewall jacket construction, kids will learn faster and ski longer than ever before.

ARTICLE NUMBER

314237

FEATURES

Jr. Power Frame
 ERA 2.0, E Base black, Structured Surface
 Also available without SLR II (ART.Nr: 314227)

DETAILS

LENGTHS 67/77/87/97/107
 117/127/137/147/157
 DIMENSIONS 111/67/96 @ Length 127
 RADIUS 8,0 @ Length 127
 PLATES SLR II Base
 BINDINGS 100682 SLR 4.5 AC Brake 74 [I]
 100678 SLR 7.5 AC Brake 78 [H]



CADDY JR

Parents know that parks and pipes are rough on their kids' gear. The Caddy Jr. stands up to the big hits and delivers durable fun.

ARTICLE NUMBER

314067

FEATURES

Sandwich Twintip Construction
Highly transparent UHM Base
Tuffwalls, PNP Rocker

DETAILS

LENGTHS 131 / 141 / 151 / 161
DIMENSIONS 116 / 81 / 106 @ Length 141
RADIUS 11,8 @ Length 141
BINDINGS 114083 SX 7.5 Brake 90 [J]



RESIDUE SLR II

The only thing sticking around after this Residue flies by will be the trail of snow dust following your smiling child taking their first jump in the park!

ARTICLE NUMBER

314117

FEATURES

Twintip Construction, UHM C Base
Structured Surface, PNP Rocker

DETAILS

LENGTHS 118 / 127 / 136 / 145 / 154
DIMENSIONS 109 / 77 / 103 @ Length 145
RADIUS 13,4 @ Length 145
PLATES SLR II Base
BINDINGS 100679 SLR 7.5 AC Brake 78 [H]



JOY SLR II

Skiing brings JOY. JOY brings laughter. Therefore, skiing brings laughter, and there's nothing better than a giggling girl on skis!

ARTICLE NUMBER

314247

FEATURES

ERA 2.0
Jr. Power Frame
E Base black
Junior Rocker

DETAILS

LENGTHS 67/77 / 87/97/107
117/127/137/147
DIMENSIONS 111 / 67 / 96 @ Length 127
RADIUS 8,0 @ Length 127
PLATES SLR II Base
BINDINGS 100683 SLR 4.5 AC Brake 74 [I]
100679 SLR 7.5 AC Brake 78 [H]



SOUPHEAD SLR II

This player is for little riders with big ambitions. When fun is the goal, look no further than the Souphead.

ARTICLE NUMBER

314307

FEATURES

Twintip Construction
E Base black
Structured Surface

DETAILS

LENGTHS 87 / 97 / 107
117 / 127 / 137
DIMENSIONS 104 / 68 / 92 @ Length 127
RADIUS 9,4 @ Length 127
PLATES SLR II Base
BINDINGS 100683 SLR 4.5 AC Brake 74 [I]
100679 SLR 7.5 AC Brake 78 [H]



MONSTER SLR II

For boys who want to have skis just like their Dads, the Monster is perfect for learning to enjoy a lifetime of skiing.

ARTICLE NUMBER

314287

FEATURES

Era 2.0, Jr. Power Frame
E Base black, Junior Rocker
Structured Surface

DETAILS

LENGTHS 67 / 77 / 87 / 97 / 107
117 / 127 / 137 / 147 / 157
DIMENSIONS 111 / 67 / 96 @ Length 127
RADIUS 8,0 @ Length 127
PLATES SLR II Base
BINDINGS 100682 SLR 4.5 AC Brake 74 [I]
100678 SLR 7.5 AC Brake 78 [H]

SKI TECHNOLOGY KERS



THE EXTRA BOOST

KERS Technology works like a turbo charger that provides additional power and acceleration by stiffening the tail of the ski in outturns. The effect: a boost, catapulting the rider into the next turn. Just like when Formula 1 pilots push a button for that extra notch of Speed. HEAD KERS Technology is an electronic, fully automatic and integrated system.

TECHNICAL BACKGROUND

HEAD KERS Technology is an evolution of the idea behind HEAD's Intelligence™ Technology. But unlike Intelligence™, KERS does not influence the torsional stiffness of the ski, KERS empowers the skis' longitudinal flex. Also KERS Technology is based on a completely new chip capable of accumulating power and keeping it in store for the right moment. Piezoelectric fibers transform kinetic energy into electrical energy which is stored in the embedded chip in the ski. Electrical energy is immediately released to areas of the ski, where additional energy is requested by the sensor. Timing and release are automatically controlled and coordinated. Depending on the flex pattern of different ski models, sensors are programmed beforehand: the more aggressive the ski has to be, the stiffer the tail will become.

Skis experience maximum flex at the end of a turn. At this moment an active microchip releases energy into the fibers of the tail. The tail of the ski then stiffens up, immediately increasing rebound for maximum acceleration at the end of the outturn.



ELECTRONIC SKI MANAGEMENT SYSTEM

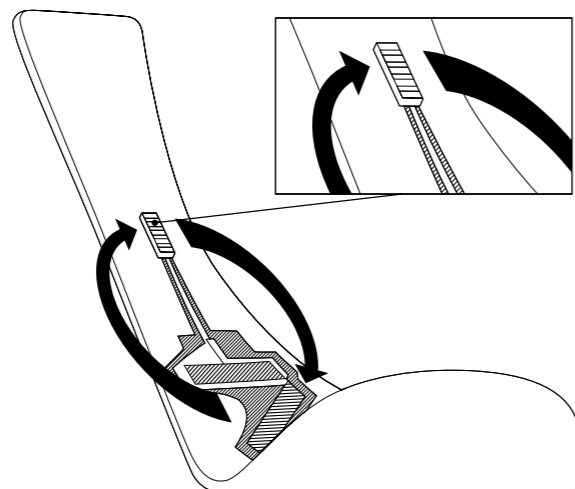

HEAD's theory of relativity: Ski performance is not an absolute measure. What you want out of a ski always depends on how and where you ride. On hard-packed slopes you want perfect edge grip. On soft snow, you want more maneuverability. Breaking the slope record you want your ski to perform differently than when you're just cruising with your friends or family. Adaptive HEAD Intelligence™ Technology helps your ski perform perfectly – both relative to terrain and your individual riding mode.

HOW IT WORKS

Intellifibers positioned at 45° in front of the binding transform mechanical impulses into electrical energy. The harder you ride, the more energy is produced. The electrical energy is led back to the Intellifibers. This causes them to stiffen up, putting more rebound and torsional stiffness into the ski.

WHAT IT DOES

Their 45° position in front of the binding increases the ski's torsional stiffness, pushing the edge into the snow in hard turns. Intelligence™ progressively stabilizes the entire ski at high speeds.

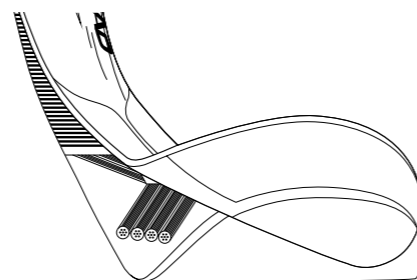

THE EXTRA BOOST

Some HEAD high-end skis boast Intelligence™ Chip Technology. Here, the electrical energy produced by the Intellifibers is not just recycled, but accumulated and released bit by bit through a pre-programmed chip – individually timed to match the oscillation properties of the ski. Thus, the effect of Intelligence™ is multiplied, providing even more performance relative to your skiing style.

JOY COLLECTION



THE SUPERLIGHT SKI THAT PACKS MORE ACTION AND JOY INTO YOUR DAY. THANKS TO GRAPHENE, THE WORLD'S LIGHTEST, THINNEST AND STRONGEST MATERIAL, SKIING WILL NO LONGER BE THE SAME. THIS REVOLUTIONARY MATERIAL ALLOWS FOR LIGHTER SKIS WITH UNPARALLELED BALANCE AND CONTROL, THAT WILL FILL YOUR DAY WITH JOY.

- 1 Top Sheet
- 2 Reinforced glass fiber
- 3 GRAPHENE
- 4 Carbon glass fiber
- 5 Koroyd
- 6 Wood Core
- 7 Sidewall
- 8 Dampening Layer
- 9 Edge
- 10 Carbon
- 11 Base

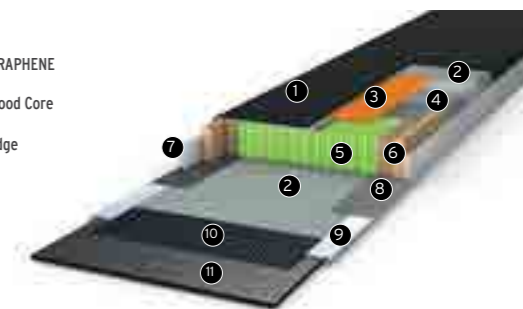

Light done right.



LIGHTNESS

THANKS TO THE LATEST SUPER LITE AND SUPER STRONG MATERIALS

True to HEAD's DNA, we remain on the forefront of ski technology. And now we are incredibly proud to introduce GRAPHENE – an incomparably light and unbelievably strong material. Layers of GRAPHENE, only a single atom thick, combine to make skis that flex and react intuitively to even the smallest inputs. When mixed with other lightweight materials like Koroyd and carbon, GRAPHENE enables weight savings of up to 350 grams.



BALANCE

THROUGH UNIQUE WEIGHT DISTRIBUTION PROFILES

With GRAPHENE we are able to manipulate the geometric profile and weight distribution of the ski in any way we like. Depending on the nature of the ski model, the type of skier, and the expected snow conditions, we fine-tune weight and flex distribution characteristics to optimize the skiing experience. Never before has a ski been more perfectly balanced or more efficient – in every model of the size run. In our new women's line, each ski's weight distribution is set up for one of two categories: "on-piste" and "off-piste".



CONTROL

WITH WOMEN'S CAMBER AND ERA 3.0

Thanks to GRAPHENE, our women's camber has a lower profile, which makes for easy turn completion and truly epic performance. And because the handling of the ERA 3.0 Rocker has been enhanced, it's not just the turns that are easier to execute – even changes from edge to edge are effortless. With GRAPHENE you always have grip and control – in every situation, through all conditions, with every move you make.

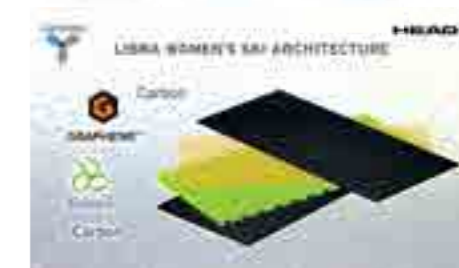

SUPERSHAPE



FEEL INNOVATION. WITH GRAPHENE EMBADDED IN THE SUPERSHAPE YOU WILL ENTER A NEW DIMENSION OF SKIING. THE UNIQUE CHARACTERISTICS OF THIS NOBEL PRICE WINNING MATERIAL ENABLES A TOTALLY DIFFERENT CONSTRUCTION OF OUR HIGH PERFORMANCE SKIS. PERFECT GRIP FROM THE FIRST RUN UNTIL THE LAST. ACCELERATE, STEER AND CHARGE AT ALL CONDITIONS BY PERFECT WEIGHT BALANCE DISTRIBUTION AND THEREFORE ACCURATE TURN INITIATION.

WC SANDWICH CAP CONSTRUCTION

- | | | |
|--------------------------|----------------------|-------------------|
| 1 Top Sheet | 2 Glass fiber fleece | 3 Titanal Layer |
| 4 Glass fiber | 5 Wood Core | 6 GRAPHENE |
| 7 Sidewall | 8 Edge | 9 Dampening Layer |
| 10 Reinforced Fiberglass | 11 Base | |

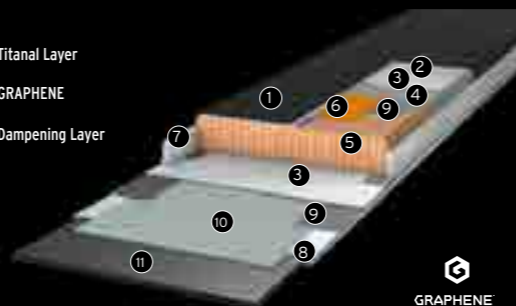

EFFORTLESS POWER

These skis have a core construction with a much larger woodcore. Due to the light-weight properties of GRAPHENE, we are able to use a thicker and wider aluminium sheet, which covers the entirety of the ski, ensuring a more reactive and powerful ride.

BALANCE

With GRAPHENE positioned in the center of the ski we have been able to reduce the thickness of the center and shift more material in the tip and tail, allowing for a ski with a truly harmonized flex distribution, easier engagement and quicker edge-to-edge changes.

CONTROL

Thanks to a thicker tip and tail it has been possible to design specific geometries for the four different shovels. Due to immediate effective edge, the ski is constantly in contact with the terrain no matter the angle.



i.Speed just wants to go faster. Clip in, hang on, and leave your comfort zone behind.



i.Rally can do it all, so get creative. There's no such thing as ice too hard, powder too soft, or turns too tight.



i.Magnum is a precision instrument for turning speed into pleasure. Go as fast as you want all day long.



i.Titan is a go-anywhere, shred-everything, multitasker. You'll need a snow cat to scrape the grin off your face.

SHOVEL ILLUSTRATIONS

A smaller shovel radius means the front contact area of the ski moves forward and engages faster into a turn.

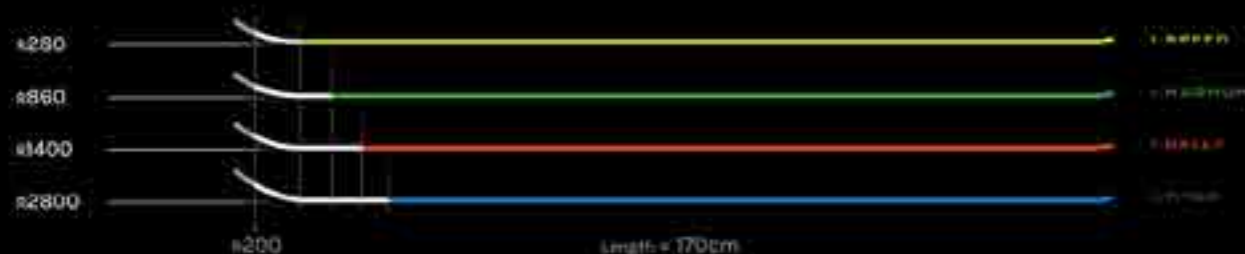

MONSTER & INSTINCT COLLECTION



THESE SKIS HAVE GRAPHENE IN THEIR DNA. GRAPHENE IS THE THINNEST AND LIGHTEST ELEMENT EVER DISCOVERED BY MANKIND. GRAPHENE IS ALSO THE STRONGEST MATERIAL ON THE PLANET, STRONGER THAN DIAMOND AND 300 TIMES STRONGER THAN STEEL. HAVE NO FEAR, THESE SKIS WILL CHEW UP AND SPIT OUT ANY TERRAIN THAT COMES YOUR WAY.

REACTIVENESS

Thanks to GRAPHENE's lightness and strength, we are able to reduce common material like wood and glass fibres to add extra titanal layers, creating a ski with unique reactivity and responsiveness.

- | | | |
|--------------------------|----------------------|-------------------|
| 1 Top Sheet | 2 Glass fiber fleece | 3 Titanal Layer |
| 4 Glass fiber | 5 Wood Core | 6 GRAPHENE |
| 7 Sidewall | 8 Edge | 9 Dampening Layer |
| 10 Reinforced Fiberglass | 11 Base | |

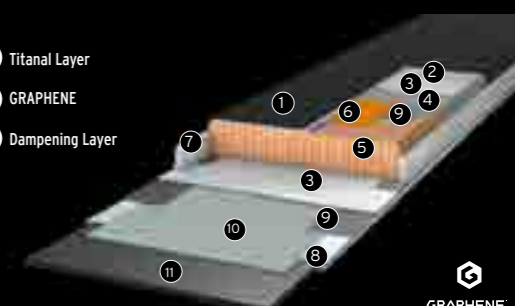

Without Graphene each ski would have 300 gramms more of material to endure the force of the titanal layers.

BALANCE

Thanks to GRAPHENE we are able to modify the balance properties of the ski to optimize the skiing experience on all terrains. The ski configurations can vary between Allride and Off-Piste.

OFF-PISTE BALANCE



ALLRIDE BALANCE



CONTROL

Thanks to GRAPHENE, our camber has a lower profile, which makes for easy turn completion and truly epic performance. And because the handling of the ERA 3.0 Rocker has been enhanced, it's not just the turns that are easier to execute – even changes from edge to edge are effortless. With GRAPHENE you always have grip and control – in every situation, through all conditions, with every move you make.



INTELLIGENCE STABILIZERS
Reduction of vibrations



ERA 3.0 PROGRESSIVE RADIUS
Up to 50% less angulation for full edge contact



LOWER PROFILE
For more solid stance



ERA 3.0 ROCKER TIP
For easy turning

SKIS TECHNOLOGY | GRAPHENE CORES SUPERSHAPE/MONSTER/INSTINCT

WC SANDWICH CAP CONSTRUCTION

Developed with the most sophisticated material known to man. The Graphene WC sandwich Cap construction, is developed with the most sophisticated material known to man. The Graphene WC Sandwich Cap Construction with a balanced mix of light Graphene and extra titanal layers, the ski combines the most extreme agility with extreme responsiveness, the ultimate performance.

- | | | |
|--------------------------|----------------------|-------------------|
| 1 Top Sheet | 2 Glass fiber fleece | 3 Titanal Layer |
| 4 Glass fiber | 5 Wood Core | 6 GRAPHENE |
| 7 Sidewall | 8 Edge | 9 Dampening Layer |
| 10 Reinforced Fiberglass | 11 Base | |

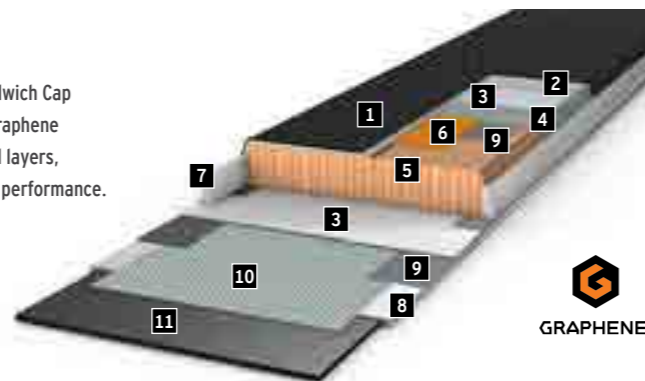

POWER SIDEWALL TI JACKET CONSTRUCTION

The Titanal layer in combination with the Graphene, creates a solid and responsive performance ski. The synthetic injected core supported with ABS sidewalls allows for a soft longitudinal flex coupled with super responsive torsional flex, thanks to the sidewall jacket.

- | | | |
|-------------------------|------------------|------------|
| 1 Top Sheet | 2 Glass fiber | 3 GRAPHENE |
| 4 Diagonal Glass fibers | 5 Synthetic Core | 6 Sidewall |
| 7 Edge | 8 Titanal | 9 Base |

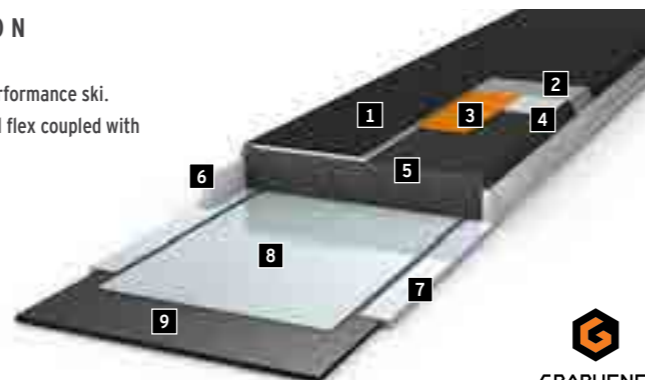

SUPERLITE POWER SIDEWALL JACKET CONSTRUCTION

A synthetic injected core supported with ABS sidewalls. This superlite construction thanks to GRAPHENE allows for a soft longitudinal flex coupled with a super responsive torsional flex, thanks to the sidewall jacket.

- | | | |
|------------------------|--------------------------|------------|
| 1 Top Sheet | 2 Glass fiber | 3 GRAPHENE |
| 4 Diagonal glass fiber | 5 Synthetic core | 6 Sidewall |
| 7 Edge | 8 Perforated steel layer | 9 Base |

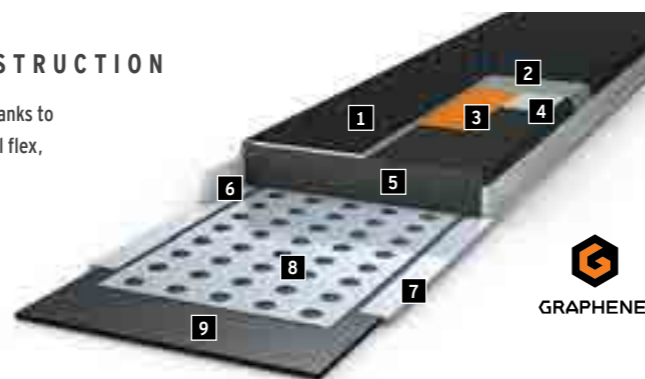

SKIS TECHNOLOGY | GRAPHENE CORES WOMEN SPECIFIC CORES

GKC SUPERLITE SANDWICH CAP CONSTRUCTION

Developed with the most sophisticated material known to man, the Superlite sandwich construction uses Graphene, KORROYD and CARBON to guarantee the lightest ski in the world without compromising on performance. The ultimate construction for a high performing women ski.

- | | | |
|----------------------|--------------------------|-------------|
| 1 Top Sheet | 2 Reinforced glass fiber | 3 GRAPHENE |
| 4 Carbon glass fiber | 5 Koroyd | 6 Wood core |
| 7 Sidewall | 8 Dampening Layer | 9 Edge |
| 10 Carbon | 11 Base | |

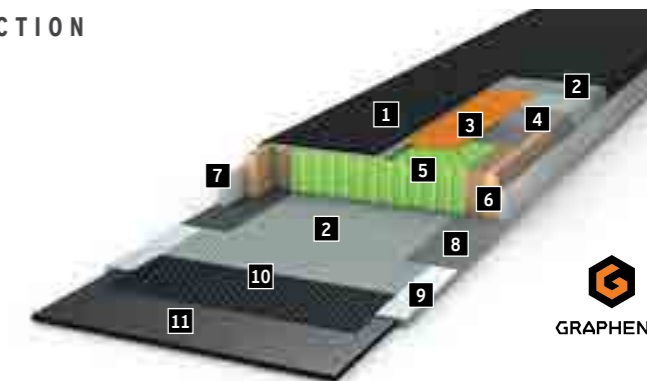

SUPERLITE SANDWICH CAP CONSTRUCTION

Thanks to the unique properties of Graphene, the Superlite Sandwich Cap Construction has had a reduction in the materials inserted with an increase in its responsiveness, allowing faster and more precise change from edge to edge. The ultimate ski for flotation and responsiveness.

- | | | |
|-------------|------------------------|--------------------------|
| 1 Top Sheet | 2 Glass fiber fleece | 3 Glass fiber |
| 4 Graphene | 5 Dampening Layer | 6 Wood core |
| 7 Sidewall | 8 Diagonal glass fiber | 9 Reinforced glass fiber |
| 10 Edge | 11 Base | |

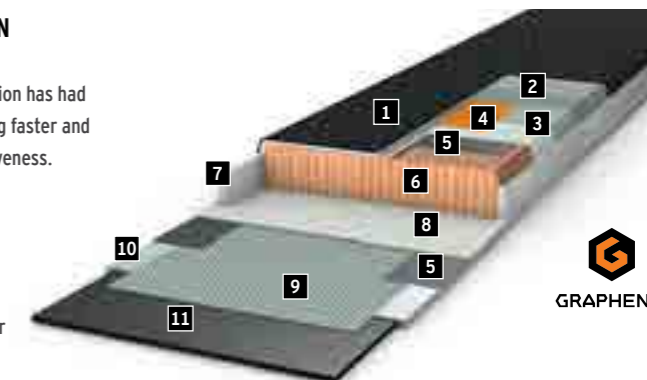

SUPERLITE POWER SIDEWALL JACKET COMPOSITE CORE

To make this construction even lighter, material from the heart has been replaced by a lighter material and a layer of Graphene has been inserted to not only insure the performance is unchanged but actually increased, as the overall thickness of the core is reduced, making it a composite that is easy and forgiving, but always precise.

- | | | |
|------------------------|------------------|--------------------------|
| 1 Top Sheet | 2 Glass fiber | 3 Graphene |
| 4 Diagonal glass fiber | 5 Synthetic core | 6 Lite core |
| 7 Sidewall | 8 Edge | 9 Reinforced glass fiber |
| 10 Base | | |

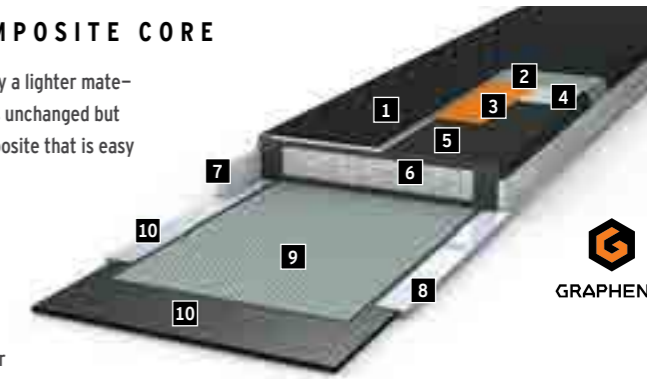

SKIS TECHNOLOGY | HEAD CORE

WC SANDWICH CAP CONSTRUCTION

A wood core sandwich construction with Titanal which combines the solid and responsive performance of the vertically laminated wood core and control offered by the Titanal. Upper layer wrapped by Cap that insures longer durability.

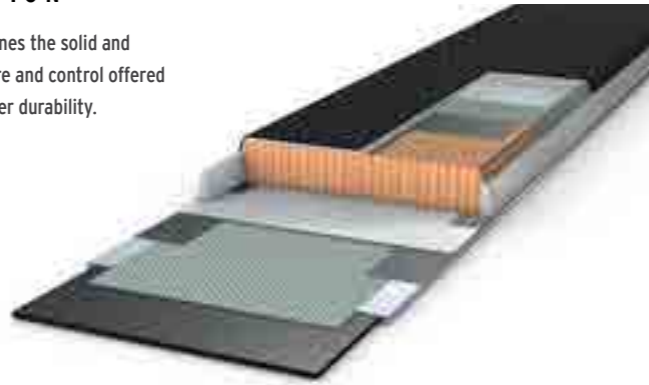

WOOD CORE CAP CONSTRUCTION

A vertically laminated wood core surrounded by a sock of fiberglass and the whole body is wrapped by a durable topsheet. This forgiving construction is ideal for ramping up the learning curve.

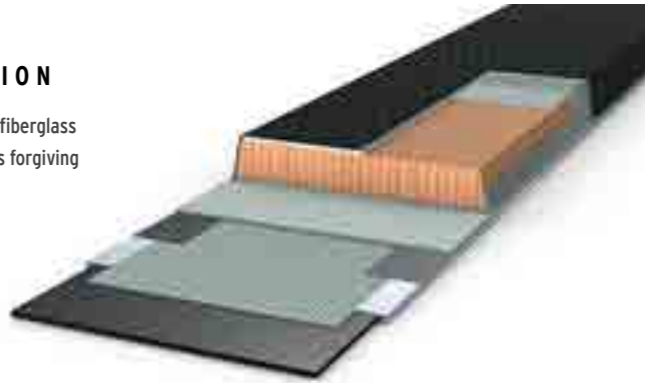

SANDWICH CAP CONSTRUCTION

Is the world cup sandwich construction with a Cap that wraps over the top edge of the sidewall to make the ski more suitable for all mountain skiing.

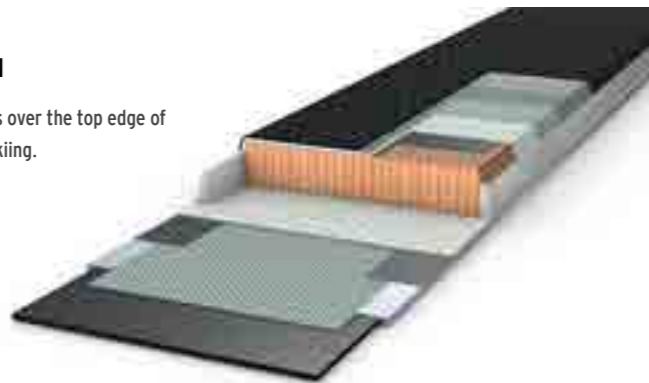

POWER SIDEWALL JACKET

A synthetic injected core supported with ABS sidewalls. This lightweight construction allows for a soft longitudinal flex coupled with a super responsive torsional flex, thanks to the sidewall jacket.



Rocker done right.

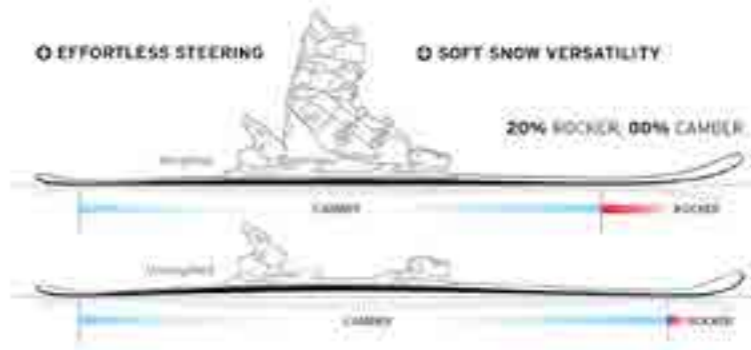

01

ALLRIDE ROCKER

A rocker who feels comfortable on the steepest slopes and deepest pow - made for skiers who feel comfortable on steepest slopes and deepest pow, and who are always ready to make the best out of every single skiing day. Allride Rocker enables superior steering and increased floatation. We place exactly the right amount of rocker in each model to ensure maximum performance for all ability levels. Steering is easier for all skiers and soft snow versatility is enhanced.



02

PNP ROCKER

Some people want to fly high - if you're one of them, be sure your ski features the PNP Rocker. Consider it a pair of wings for skis, developed in the HEAD freestyle laboratory. Our Park & Pipe Rocker incorporates tip and tail rise with regular camber underfoot. PNP gives skis a significant amount of pop and energy for boosting tricks. So dive in, go bigger, fly further, and rock the park and pipe as hard as you can.



03

SPEED ROCKER

For perfect handling on hardpack - a slight tip rise on a ski with standard camber which means great performance, easy turn initiation, and high versatility on soft snow. 10% rocker and 90% camber is just enough to take the sting out of the edges, while keeping the bite you need to turn. Speed Rocker turns HEAD performance skis into a weapon of speed with power steering. It's fast. Are you?



04

TNT ROCKER

For more powerful freeriding - Tip & Tail Rise meet partial camber! The recipe for great float and freedom in powder with enough standing power to enjoy those days you didn't pray for snow. Really the best of both worlds. 40% Rocker is radical enough to satisfy the freerider's soul. 60% Camber helps keep your speed and your budget in check - because with the versatility of TNT rocker, you'll have to buy one less ski for your quiver.



05

JUNIOR ROCKER

For perfect allride performance. Kids don't like compromises. But they don't like sticking to decisions either. One day they're a rockstar. And the next day they want to be a bunny. With 20% rocker and 80% camber, kids get tons of float, easy turn initiation, and plenty of speed and control. HEAD's Junior Rocker simply works for anyone, anywhere.



SKIS TECHNOLOGY | ERA 3.0



ERA 3.0

Imagine a ski that performs for everyone, anywhere: One for all. All in one. HEAD ERA 3.0 is not your one-dimensional «Have a problem? We fix it!» technology. ERA 3.0 is a combination of technologies, shape and geometry. Think Rocker, think Radius, think Rebound. Think 3-dimensional.



ALLRIDE ROCKER

For superior steering and increased floatation. We place a highly targeted amount of rocker in each model to ensure maximum performance for all ability levels. Steering is easier for all skiers and soft snow versatility is enhanced.

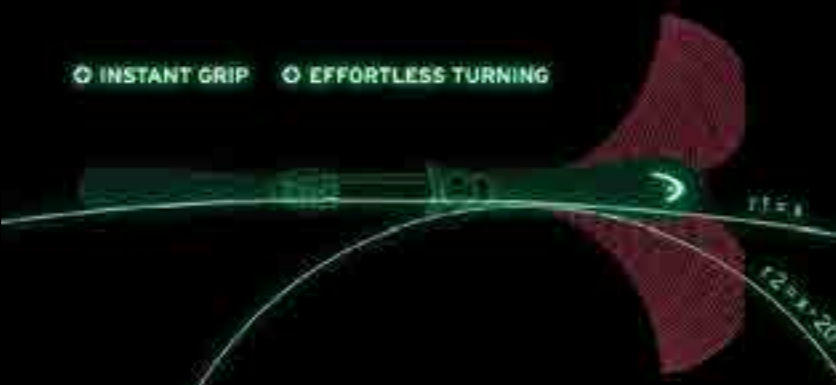

PROGRESSIVE RADIUS

For tremendous turning. Regular rocker makes skiers place their ski further on edge to have it touch from tip-to-tail. With progressive radius, up to 50 % less angulation is needed to enjoy full edge contact. More edge on the snow = more edge grip.



INTELLIRISE REBOUND

For targeted stability. We move our legendary piezoelectric Intellifibers to the tip of the ski. The nasty tip vibrations found on regular rockers are not found here. These skis are too smart for that.

ERA 2.0

THE LITTLE BROTHER OF ERA 3.0. It is everything ERA 3.0 has to offer as far as design, performance and geome-

try integration, but without the addition of "Rebound" with its piezoelectric Intellifibers. While we do want to see kids

experience skiing performance at the highest level, they should have the best possible tools to learn and perform.



SKIS TECHNOLOGY | FRAMEWALL



FRAMEWALL

The extraordinary stressing of Park&Pipe skis generally result in fast abrasion and easy chipping of the top sheet. This problem has been solved by the all new FRAMEWALL. The three dimensional build of the side-walls covers the skis top sheet and prevents it from chipping and other external hazards, which results in delamination. The FRAMEWALL is the first 360 protector on a ski, that increases the skis durability and performance considerably!

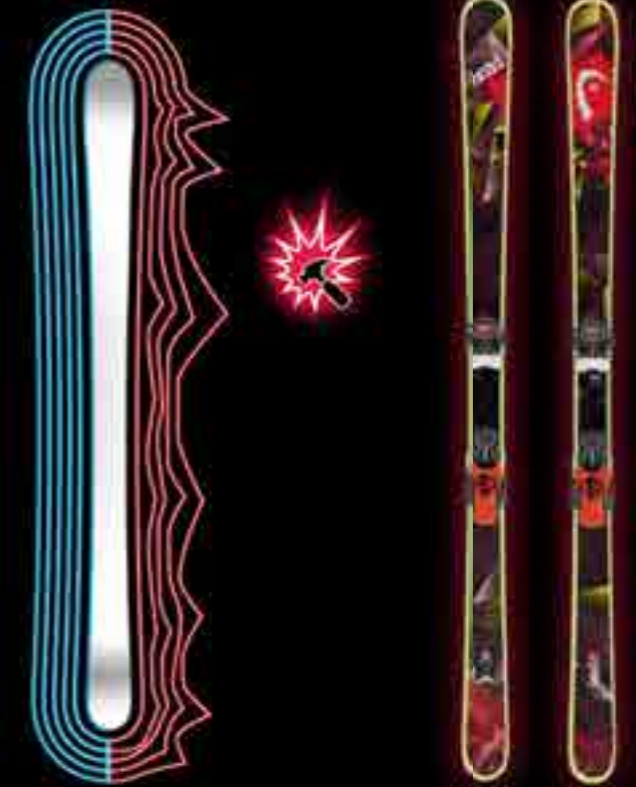

FREEFLEX EVO

Freeflex EVO reduces the impact on the natural ski flex to a minimum. Decreased forward pressure, completely redesigned new roller pincer systems and wings, plus an intelligent gliding element all add up to the rEVolution of racing: fastest time, from the starting gate to the finish line with Freeflex EVO.



LOWER WEIGHT - MORE FUN

What is ideal: a lower weight or improved safety? This question is a thing of the past when it comes to choosing the perfect touring binding. Tyrolia's new AAmbition AT binding combines both desired features by using the high tech material Carbon© in the mid part of the binding. Constant stability at a significantly reduced binding weight (200g) make the Tyrolia AAmbition Carbon an AT binding with proven downhill performance and safety features. Its benefits of very low weight are highly valued when hiking and touring the back country.

Available in 3 Lengths: SHORT (265-295mm), MEDIUM (295-325mm) and LONG (315-345mm).





BOOTS

WINTER COLLECTION 2017-18



HEAD[®]



POWER EFFICIENT DESIGN

Better skiing
with less effort

The HEAD design concept is inspired by the obsession to make skiing more fun, easier while using and with less energy. This is obtained by a naturally centered, and balanced stance, combined with a structure that maximizes the energy transmission to the skis.



Hi-Top Tech

Direct contact between leg and shell provides the maximum energy transmission and ski control.

Duo Flex

The Duo Flex drivers enable a progressive and reactive flex with precise ski control through all phases of the turn.

Control Frame

An innovative profile and two different materials provide a perfect synthesis of comfort and rearward support, and energy transmission.

FEEL THE ADVANTEDGE

5° 30% More power transfer
40% More reactivity & rebound

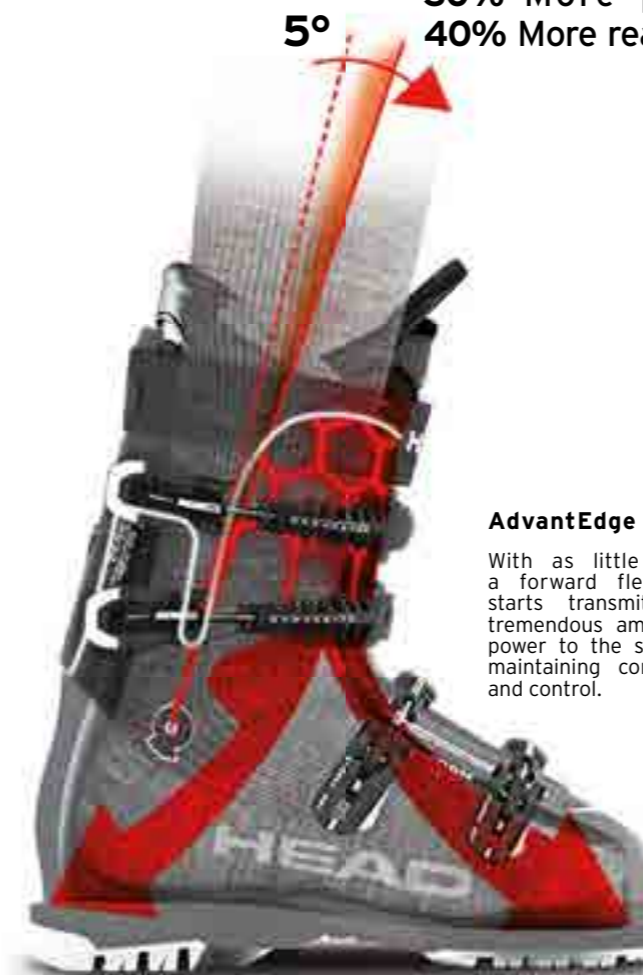

AdvantEdge Boots

With as little as 5° a forward flex skier starts transmitting a tremendous amount of power to the ski while maintaining confidence and control.

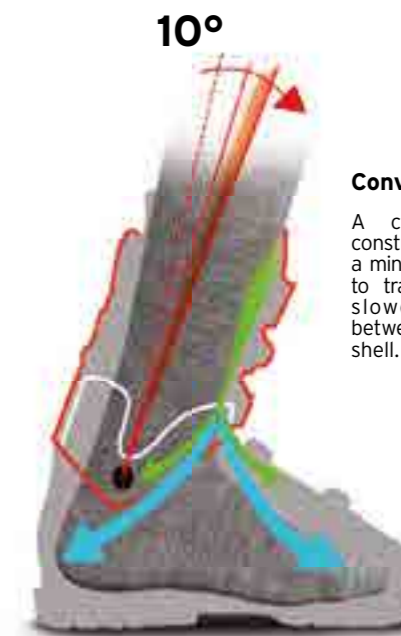

Conventional Boots

A conventionally constructed boot requires a minimum flex of 10° to transmit energy, with slower transmission between the cuff and shell.



Super Easy Entry

Hi Top tech provides the easiest hand entry and exit and prevents foot pinching by holding the boot tongue in the correct position inside the boot.



FORMED TO YOUR FOOT

100% CUSTOMIZABLE FIT SYSTEM

FORM FIT



New FormFit plastics formulas hold stretches better than ever before for a perfect comfort with improved balance and control.



PERFECT FIT is the new revolutionary system that ensures comfortable, performances-oriented customization in HEAD's superb ski boots.

HOW DOES IT WORK?



THE NEW HEAD SOLES FOR VECTOR EVO AND ADVANT EDGE



High-profiled slip-resistant sole



Increased walking comfort and improved natural roll thanks to a curved rubber sole

GRIP WALK



GRIP WALK cod. 60120015

No height adjustment needed for specific Grip Walk binding

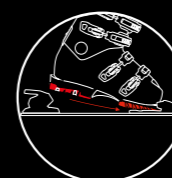

GRIPWALK. COMPATIBLE WITH:
 - Alpine ski bindings with the additional Gripwalk marking
 - Bindings that accept alpine touring boots according to ISO 9523

WALK SOLE

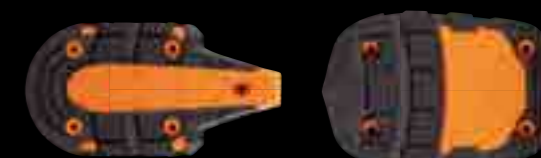

WALK SOLE cod. 60119545

WALK SOLE. COMPATIBLE WITH:
 - Alpine ski bindings which are marked to work with Walk Soles or Walk To Ride soles
 - Bindings that accept alpine touring boots according to ISO 9523

HEAD CANTING SYSTEM

BOOT COMPATIBILITY:
 Compatible with VECTOR EVO and ADVANTEDGE

Cod. 60119552

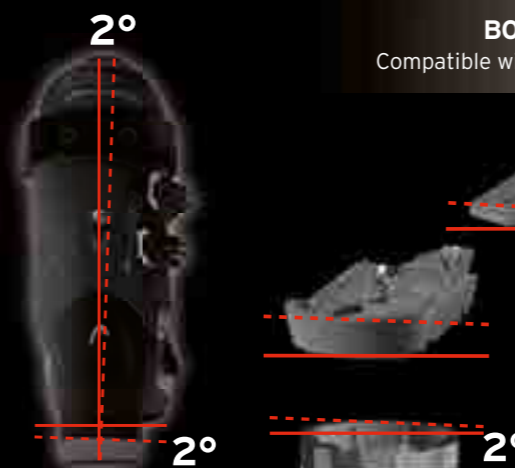

HEAD offers the following solutions:

- 2,0°
- 1,5°
- 1,0°
- 0,5°

**RAPTOR 140S RS****ARTICLE NUMBER**

607007

FEATURES

Flex Performance tuning
 Racing Double canting
 Rear support tuning
 FIS approved sole thickness
 Low racing wedge

LINER

Performance Pro liner
 HP frame footbed
 40 mm Double Power
 Booster velcro strap

BUCKLES

4 screwed micro-adjustable
 Spineflex racing alloy buckles
 Low profile buckles

DETAILS

LEVEL Professional

FLEX INDEX 150/140/130

SIZES 220-225-230-...
 -295-305

SHELL PU Performance

LAST RS 1800cc

Last	94	96	98
Size	25.5	26.5	27.5

COLOR White

RACE BALANCE

Forward Lean 16°, Ramp Angle 4°

RAPTOR 120S RS**ARTICLE NUMBER**

607008

FEATURES

Racing flex tuning
 Racing Double canting
 FIS approved sole thickness
 Low racing wedge

LINER

HeatFit Pro liner
 HP frame footbed
 40 mm velcro strap

BUCKLES

4 micro-adjustable Spine-Tech
 alloy buckles
 Low profile buckles

DETAILS

LEVEL Professional

FLEX INDEX 120/110

SIZES 220-225-230-...
 -295-305

SHELL PU

LAST RS 1800cc

Last	94	96	98
Size	25.5	26.5	27.5

COLOR White

RACE BALANCE

Forward Lean 16°, Ramp Angle 4°

**RAPTOR 110S RS W****ARTICLE NUMBER**

607014

FEATURES

Flex tuning
 Racing Double canting
 FIS approved sole thickness
 Low racing wedge

LINER

Women's HeatFit Pro liner
 HP frame footbed
 40 mm velcro strap

BUCKLES

4 micro-adjustable Spine-Tech
 alloy buckles
 Low profile buckles

DETAILS

LEVEL Professional

FLEX INDEX 110/100

SIZES 220-225-230-...-275

SHELL PU - JR Cuff

LAST RS 1800cc

Last	92	94	96
Size	24.5	25.5	26.5

COLOR Black

RACE BALANCE

Forward Lean 16°, Ramp Angle 4°

RAPTOR 90 RS W**ARTICLE NUMBER**

607018

FEATURES

Flex tuning
 Racing Double Canting
 FIS approved sole thickness
 Low racing wedge

LINER

Women's HeatFit Pro liner
 HP frame footbed
 40 mm velcro strap

BUCKLES

4 micro-adjustable alloy buckles
 Low profile buckles

DETAILS

LEVEL Expert

FLEX INDEX 90/80

SIZES 220-225-230-...-275

SHELL PU - JR Cuff

LAST RS 1800cc

Last	92	94	96
Size	24.5	25.5	26.5

COLOR Gray

RACE BALANCE

Forward Lean 16°, Ramp Angle 4°

**RAPTOR 80 W****ARTICLE NUMBER**

607019

FEATURES

Flex tuning
 Racing Double Canting
 FIS approved sole thickness
 Low racing wedge

LINER

Women's HeatFit Pro liner
 HP frame footbed
 40 mm velcro strap

BUCKLES

4 micro-adjustable alloy buckles
 Low profile buckles

DETAILS

LEVEL Expert

FLEX INDEX 80/70

SIZES 220-225-230-...-275

SHELL PU - JR Cuff

LAST RS 1800cc

Last	92	94	96
Size	24.5	25.5	26.5

COLOR Turquoise

RACE BALANCE

Forward Lean 16°, Ramp Angle 4°





HAMMER 110

ARTICLE NUMBER

607023

FEATURES

Triad ergoflex shell
Shock absorbing canting
Shock absorbing wedge
Form Fit
Replaceable tongue
Biinjected pads, Rubber grip sole
Flex Adjust

LINER

Perfect Fit Pro liner
Shock-absorber footbed
50 mm velcro strap
Gel shin saver
Shock absorbing toe-box

BUCKLES

3 micro-adjustable alloy buckles

DETAILS

LEVEL Advanced

FLEX INDEX 110/100

SIZES 240-245-...

-290-295

SHELL PU/SL

LAST FR 1800cc

Last	96	98	100
Size	25.5	26.5	27.5

COLOR Red/ black

ERGO BALANCE

Forward Lean 16°, Ramp Angle 4°



THRASHER 100

ARTICLE NUMBER

607024

FEATURES

Triad ergoflex shell
Shock absorbing canting
Shock absorbing wedge
Form Fit
Replaceable tongue, Flex tuning

LINER

Perfect Fit Pro liner
Shock-absorber footbed
50 mm velcro strap
Gel shin saver, Shock absorbing spoiler, Shock absorbing toebox

BUCKLES

2 micro-adjustable alloy buckles

DETAILS

LEVEL Professional

FLEX INDEX 100/90

SIZES 240-245-...-290-295

SHELL PU/SL

LAST FR 1800cc

Last	96	98	100
Size	25.5	26.5	27.5

COLOR Black-red

ERGO BALANCE

Forward Lean 16°, Ramp Angle 4°

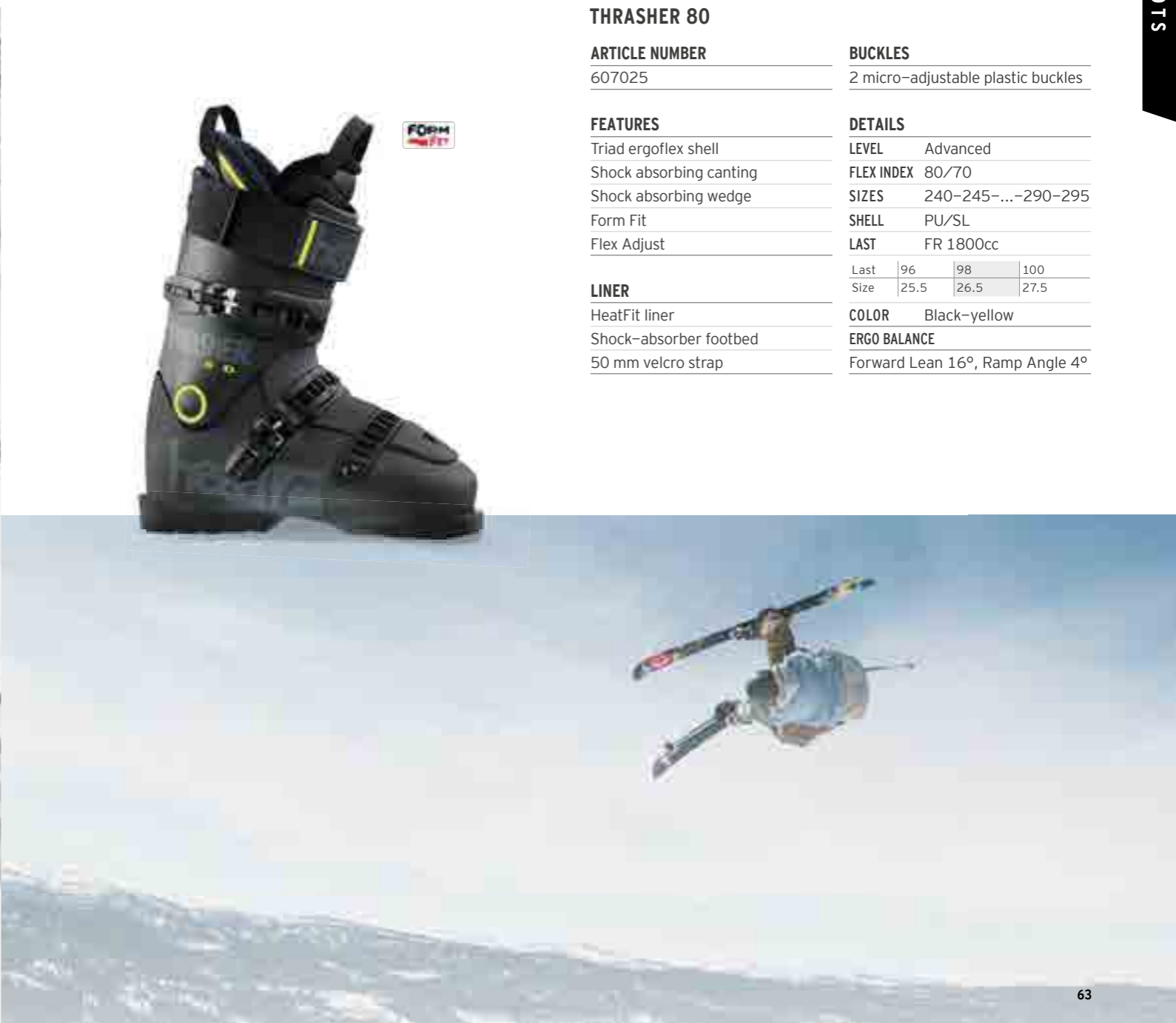

THRASHER 80

ARTICLE NUMBER

607025

FEATURES

Triad ergoflex shell
Shock absorbing canting
Shock absorbing wedge
Form Fit
Flex Adjust

LINER

HeatFit liner
Shock-absorber footbed
50 mm velcro strap

BUCKLES

2 micro-adjustable plastic buckles

DETAILS

LEVEL Advanced

FLEX INDEX 80/70

SIZES 240-245-...-290-295

SHELL PU/SL

LAST FR 1800cc

Last	96	98	100
Size	25.5	26.5	27.5

COLOR Black-yellow

ERGO BALANCE

Forward Lean 16°, Ramp Angle 4°



VECTOR EVO 130S

ARTICLE NUMBER

607032

FEATURES

Bi-Inj. dynamic frame
Easy entry shell design
Racing flex tuning, Single canting
Rear support tuning
Form Fit, FOAM wedge
Walk sole compatible
Grip walk sole compatible
HEAD Canting system
sole compatible

LINER

EVO Perfect Fit HD PRO liner
HP frame footbed
40 mm Double Power
Booster velcro strap
Gel Shin Saver

BUCKLES

4 micro-adjustable Spineflex alloy
buckles, 2 Double power levers
1 Supermacro ratchet
Low profile buckles

DETAILS

LEVEL Professional
FLEX INDEX 130/120
SIZES 250-255-...-305
310-320
SHELL PU
LAST S 1850cc

Last	98	100	102
Size	25.5	26.5	27.5

COLOR Antracite/black-yellow

EVO BALANCE

Forward Lean 14°, Ramp Angle 4°



VECTOR EVO 110S W

ARTICLE NUMBER

607040

FEATURES

Bi-Inj. dynamic frame
Easy entry shell design
Racing flex tuning, Single canting
Rear support tuning, Form Fit
Walk sole compatible
Grip walk sole compatible
HEAD Canting system
sole compatible

LINER

Women's EVO Perfect Fit HD liner
HP frame footbed
30 mm velcro strap

BUCKLES

4 micro-adjustable Spine-Tech
alloy buckles, 2 Double Power
levers, 1 Supermacro ratchet

DETAILS

LEVEL Expert
FLEX INDEX 110/100
SIZES 230-235-...-275
SHELL PU/SL
LAST S 1850cc

Last	96	98	100
Size	24.5	25.5	26.5

COLOR Antracite/black-yellow

EVO BALANCE

Forward Lean 14°, Ramp Angle 4°



VECTOR EVO 120S

ARTICLE NUMBER

607035 Antracite/black-green
607034 White/green

FEATURES

Bi-Inj. dynamic frame
Easy entry shell design
Racing flex tuning, Single canting
Rear support tuning, Form Fit
Walk sole compatible
Grip walk sole compatible
HEAD Canting system
sole compatible

LINER

EVO Perfect Fit HD liner
HP frame footbed
40 mm velcro strap

BUCKLES

4 micro-adjustable Spine-Tech
alloy buckles, 2 Double power
levers, 1 Supermacro ratchet
Low profile buckles

DETAILS

LEVEL Professional
FLEX INDEX 120/110
SIZES 250-255-...-305
SHELL PU
LAST S 1850cc

Last	98	100	102
Size	25.5	26.5	27.5

COLOR Antracite/black-green

White/green

EVO BALANCE

Forward Lean 14°, Ramp Angle 4°



VECTOR EVO 90 W

ARTICLE NUMBER

607071

607072

FEATURES

Bi-Inj. dynamic frame
Easy entry shell design
Racing flex tuning, Single canting
Rear support tuning, Form Fit
Walk sole compatible
Grip walk sole compatible
HEAD Canting system
sole compatible

LINER

Women's EVO Perfect Fit S liner
HP frame footbed
30 mm velcro strap

BUCKLES

4 micro-adjustable alloy buckles
1 Supermacro ratchet

DETAILS

LEVEL Expert
FLEX INDEX 90/80
SIZES 230-235-...-275
SHELL PU/SL
LAST S 1850cc

Last	96	98	100
Size	24.5	25.5	26.5

COLOR Antracite/black

Gray/white

EVO BALANCE

Forward Lean 14°, Ramp Angle 4°

VECTOR EVO 110

ARTICLE NUMBER

607061

FEATURES

Bi-Inj. dynamic frame
Easy entry shell design
Racing flex tuning, Single canting
Rear support tuning, Form Fit
Walk sole compatible
Grip walk sole compatible
HEAD Canting system
sole compatible

LINER

EVO Perfect Fit S liner
HP frame footbed
40 mm velcro strap

BUCKLES

4 micro-adjustable alloy buckles
1 Supermacro ratchet
Low profile buckles

DETAILS

LEVEL Expert
FLEX INDEX 110/100
SIZES 250-255-...-305
SHELL PU/SL
LAST S 1850cc

Last	98	100	102
Size	25.5	26.5	27.5

COLOR Antracite/black-red

EVO BALANCE

Forward Lean 14°, Ramp Angle 4°





CHALLENGER 120

ARTICLE NUMBER
607026

FEATURES

Bi-Inj. energy frame +
Adaptive fit technology
Power ski-hike mechanism
Easy entry shell design
Rear support tuning
Single canting

LINER

Perfect Fit HP liner, HP frame
footbed, 40 mm velcro strap

BUCKLES

4 micro-adjustable alloy buckles
2 Double Power levers
1 Supermacro ratchet
Low profile buckles

DETAILS

LEVEL Expert
FLEX INDEX 120
SIZES 250-255...-305
SHELL PU/SL
LAST S 2000cc

Last	97-99	99-101	101-103
Size	25.5	26.5	27.5

COLOR Black/anthr.-yellow
VERSO BALANCE
Forward Lean 16°, Ramp Angle 6°



ADVANT EDGE 125S

ARTICLE NUMBER
607102

FEATURES

Bi-Inj. control frame
Hi-Top Tech, Duo Flex
Easy entry shell design
Stiffer/softer flex adjustment
Single canting, Form Fit
Walk sole compatible
Grip walk sole compatible
HEAD Canting system
sole compatible

LINER

Perfect Fit HD PRO liner
Sport frame footbed, 40 mm
Double Power Booster velcro strap

BUCKLES

4 micro-adjustable Spine-Tech
alloy buckles, 2 Double Power
levers, 1 Supermacro ratchet
Low profile buckles

DETAILS

LEVEL Advanced
FLEX INDEX 125/115
SIZES 250-255...-305-
310-320-330-340
SHELL PU
LAST C 2100cc

Last	100	102	104
Size	25.5	26.5	27.5

COLOR Anthr./black
ALLRIDE BALANCE
Forward Lean 14°, Ramp Angle 5°



CHALLENGER 110

ARTICLE NUMBER
607028

FEATURES

Bi-Inj. energy frame +
Adaptive fit technology
Power ski-hike mechanism
Easy entry shell design
Rear support tuning
Single canting

LINER

Perfect Fit S liner
HP frame footbed
40 mm velcro strap

BUCKLES

4 micro-adjustable alloy buckles
1 Supermacro ratchet
Low profile buckles

DETAILS

LEVEL Expert
FLEX INDEX 110
SIZES 250-255...-305
SHELL SL
LAST S 2000cc

Last	97-99	99-101	101-103
Size	25.5	26.5	27.5

COLOR Black/anthr.-red
VERSO BALANCE
Forward Lean 16°, Ramp Angle 6°



ADVANT EDGE 105

ARTICLE NUMBER
607103

FEATURES

Bi-Inj. control frame
Hi-Top Tech, Duo Flex
Easy entry shell design
Stiffer/softer flex adjustment
Single canting, Form Fit
Walk sole compatible
Grip Walk sole compatible
HEAD Canting system
sole compatible

LINER

Perfect Fit HD liner
Sport frame footbed
40mm velcro strap

BUCKLES

4 micro-adjustable alloy buckles
2 Double Power levers, 1 Supermacro
ratchet, Low profile buckles

DETAILS

LEVEL Advanced
FLEX INDEX 105/95
SIZES 250-255...-305
SHELL PU/SL
LAST C 2100cc

Last	100	102	104
Size	25.5	26.5	27.5

COLOR Red/Black
ALLRIDE BALANCE
Forward Lean 14°, Ramp Angle 5°



CHALLENGER 100 W

ARTICLE NUMBER
607029

FEATURES

Bi-Inj. energy frame
Adaptive fit technology
Power ski-hike mechanism
Easy entry shell design
Rear support tuning
Single canting

LINER

Women's Perfect Fit S liner
HP frame footbed
40 mm velcro strap

BUCKLES

4 micro-adjustable alloy buckles
1 Supermacro ratchet

DETAILS

LEVEL Expert
FLEX INDEX 100
SIZES 230-235...-270-275
SHELL SL
LAST S 2000cc

Last	97-95	99-97	101-99
Size	24.5	25.5	26.5

COLOR Black/anthr.-fucsia
VERSO BALANCE
Forward Lean 16°, Ramp Angle 6°



ADVANT EDGE 95

ARTICLE NUMBER
607116 Anthr./black- green
607121 Yellow/black

FEATURES

Bi-Inj. control frame
Hi-Top tech, Duo Flex
Easy entry shell design
Single canting
Stiffer/softer flex adjust
Walk sole compatible
Grip walk sole compatible
HEAD Canting system
sole compatible

LINER

Perfect Fit S liner, Sport frame
footbed, 40 mm velcro strap

BUCKLES

4 micro-adjustable alloy buckles,
2 Double Power levers, 1 Super
macro ratchet, Low profile buckles

DETAILS

LEVEL Advanced
FLEX INDEX 95/85
SIZES 250-255...-305
SHELL SL
LAST C 2100cc

Last	100	102	104
Size	25.5	26.5	27.5

COLOR Anthr./black- green
Yellow/black
ALLRIDE BALANCE
Forward Lean 14°, Ramp Angle 5°



ADVANT EDGE 85

ARTICLE NUMBER
607148

FEATURES
Bi-Inj. control frame
Hi-Top tech, Duo Flex
Easy entry shell design
Single canting
Walk sole compatible
Grip walk sole compatible
HEAD Canting system sole compatible

LINER
HeatFit liner, Sport frame footbed
40 mm velcro strap

BUCKLES
4 micro-adjustable alloy buckles
1 Supermacro ratchet
Low profile buckles

DETAILS
LEVEL Intermediate
FLEX INDEX 85
SIZES 250-255-260-265-...-305
SHELL SL
LAST C 2100cc

Last	100	102	104
Size	25.5	26.5	27.5

COLOR Anthr./black
ALLRIDE BALANCE
Forward Lean 14°, Ramp Angle 5°



ADVANT EDGE 75

ARTICLE NUMBER
607189 Antracite/black-red
607192 White/ black-yellow

FEATURES
Bi-Inj. control frame
Hi-Top tech, Duo flex
Easy entry shell design
Single canting
Walk sole compatible
Grip walk sole compatible
HEAD Canting system sole compatible

LINER
Comfort liner
Sport frame footbed
40 mm velcro strap

BUCKLES
4 micro-adjustable plastic buckles
1 Supermacro ratchet
Light buckle

DETAILS
LEVEL Intermediate
FLEX INDEX 75
SIZES 250-255-260-265-...-305
SHELL SL
LAST C 2100cc

Last	100	102	104
Size	25.5	26.5	27.5

COLOR Antracite/black-red
White/ black-yellow
ALLRIDE BALANCE
Forward Lean 14°, Ramp Angle 5°



ADVANT EDGE 95 W

ARTICLE NUMBER
607106

FEATURES
Bi-Inj. control frame, Hi-Top tech
Duo flex, Easy entry shell design
Stiffer/softer flex adjust
Single canting
Double adjustable cuff, Form fit
Walk sole compatible
Grip walk sole compatible
HEAD Canting system sole compatible

LINER
Women's Perfect Fit HD liner
Women auto adaptive tech
Fleece lining, Sport frame footbed
30 mm velcro strap

BUCKLES
4 micro-adjustable alloy buckles
2 Double Power levers
1 Supermacro ratchet

DETAILS
LEVEL Advanced
FLEX INDEX 95/85
SIZES 220-225-230-235-...-275
SHELL PU/SL
LAST C 2100cc

Last	98	100	102
Size	24.5	25.5	26.5

COLOR Trs. anthr/black
ALLRIDE BALANCE
Forward Lean 14°, Ramp Angle 5°



ADVANT EDGE 85 W

ARTICLE NUMBER
607126 Anthr./black
607127 White/gray-yellow

FEATURES
Bi-Inj. control frame, Hi-Top tech
Duo flex, Easy entry shell design
Stiffer/softer flex adjust
Single canting, Women extra:
Double adjustable cuff
Walk sole compatible
Grip walk sole compatible
HEAD Canting system sole compatible

LINER
Women's Perfect Fit S liner
Women auto adaptive tech
Fleece lining, Sport frame footbed
30 mm velcro strap
Prepared for heating system

BUCKLES
4 micro-adjustable alloy buckles
2 Double Power levers
1 Supermacro ratchet

DETAILS
LEVEL Advanced
FLEX INDEX 85/75
SIZES 220-225-230-235-...-275
SHELL SL
LAST C 2100cc

Last	98	100	102
Size	24.5	25.5	26.5

COLOR Anthr./black
White/gray-yellow
ALLRIDE BALANCE
Forward Lean 14°, Ramp Angle 5°



**ADVANT EDGE 75 W****ARTICLE NUMBER**

607149

FEATURES

Bi-Inj. control frame, Hi-Top tech
 Duo flex, Easy entry shell design
 Single canting, Women extra:
 Double adjustable cuff
 Walk sole compatible
 Grip walk sole compatible
 HEAD Canting system
 sole compatible

LINER

Women's HeatFit liner
 Fleece lining, Sport frame footbed
 30 mm velcro strap
 Prepared for heating system

BUCKLES

4 micro-adjustable alloy buckles
 1 Supermacro ratchet

DETAILS

LEVEL Intermediate

FLEX INDEX 75

SIZES 220-225-230-235-
 ...-275

SHELL SL

LAST C 2100cc

Last	98	100	102
Size	24.5	25.5	26.5

COLOR Anthr./black-turq.

ALLRIDE BALANCE

Forward Lean 14°, Ramp Angle 5°

ADVANT EDGE 65 W**ARTICLE NUMBER**

607193 White/gray
 607196 Anthr./black

FEATURES

Bi-Inj. control frame, Hi-Top tech
 Duo flex, Easy entry shell design
 Single canting, Women extra:
 Double adjustable cuff
 Walk sole compatible
 Grip walk sole compatible
 HEAD Canting system
 sole compatible

LINER

Comfort liner, Fleece lining
 Sport frame footbed
 30 mm velcro strap

BUCKLES

4 micro-adjustable plastic buckles
 1 Supermacro ratchet
 Light buckle

DETAILS

LEVEL Intermediate

FLEX INDEX 65

SIZES 220-225-230-235-
 ...-275

SHELL SL

LAST C 2100cc

Last	98	100	102
Size	24.5	25.5	26.5

COLOR White/gray
 Anthr./black

ALLRIDE BALANCE

Forward Lean 14°, Ramp Angle 5°

**CUBE3 90****ARTICLE NUMBER**

606215

FEATURES

Integrated autoskiwalk

LINER

SuperHeat3 quick entry liner
 Sport frame footbed
 35 mm velcro strap

BUCKLES

2 micro-adjustable alloy buckles
 1 micro-adjustable wide-body
 alloy buckle
 1 Supermacro ratchet

DETAILS

LEVEL Advanced

FLEX INDEX 90

SIZES 250-255-260-
 265-...-305

SHELL PU/SL

LAST EC 2200cc

Last	102	104	106
Size	25.5	26.5	27.5

COLOR Black/anth.

COMFORT BALANCE

Forward Lean 16°, Ramp Angle 6°

CUBE3 80**ARTICLE NUMBER**

606223

FEATURES

Integrated autoskiwalk

LINER

HeatFit quick entry liner
 Sport frame footbed
 35 mm velcro strap

BUCKLES

2 micro-adjustable plastic buckles
 1 micro-adjustable wide-body
 alloy buckles
 1 Supermacro ratchet

DETAILS

LEVEL Intermediate

FLEX INDEX 80

SIZES 250-255-260-
 265-...-305

SHELL SL

LAST EC 2200cc

Last	102	104	106
Size	25.5	26.5	27.5

COLOR Black/anth. - yellow

COMFORT BALANCE

Forward Lean 16°, Ramp Angle 6°

**CUBE3 70****ARTICLE NUMBER**

606234

FEATURES

Integrated autoskiwalk

LINER

Comfort quick entry liner
 Sport frame footbed
 35 mm velcro strap

BUCKLES

3 micro-adjustable plastic buckles
 1 Supermacro ratchet

DETAILS

LEVEL Intermediate

FLEX INDEX 70

SIZES 250-255-260-
 265-...-320

SHELL SL

LAST EC 2200cc

Last	102	104	106
Size	25.5	26.5	27.5

COLOR Black/anth.-red

COMFORT BALANCE

Forward Lean 16°, Ramp Angle 6°





CUBE3 80 W

ARTICLE NUMBER

606218

FEATURES

Integrated autoskiwalk

LINER

Women's SuperHeat3 quick entry liner, Sport frame footbed
35 mm velcro strap

BUCKLES

2 micro-adjustable alloy buckles
1 micro-adjustable wide-body alloy buckles
1 Supermacro ratchet

DETAILS

LEVEL Advanced

FLEX INDEX 80

SIZES 230-235-...-275

SHELL PU/SL

LAST EC 2200cc

Last	100	102	104
Size	24.5	25.5	26.5

COLOR Anth./black

COMFORT BALANCE

Forward Lean 16°, Ramp Angle 6°



DREAM 100 W

ARTICLE NUMBER

607237

FEATURES

Stiffer/softer flex adjustment
Adjustable wedge arch support
Double canting, Double adjustable profile, Woman-specific supportive heel option, Form Fit

LINER

Women's Perfect Fit HP liner
Fur lining, Self-shaping footbed with Sanitized®, 30 mm velcro strap, Prepared for heating system

BUCKLES

4 micro-adjustable alloy buckles
2 Double Power levers
1 Supermacro ratchet

DETAILS

LEVEL Professional

FLEX INDEX 100/90

SIZES 220-225-230-...-275

SHELL PU

LAST WP 1950cc

Last	96	98	100
Size	24.5	25.5	26.5

COLOR Black-turquoise



CUBE3 70 W

ARTICLE NUMBER

606224

FEATURES

Integrated autoskiwalk

LINER

Women's HeatFit quick entry liner
Sport frame footbed
35 mm velcro strap

BUCKLES

2 micro-adjustable plastic buckles
1 micro-adjustable wide-body alloy buckle, 1 Supermacro ratchet

DETAILS

LEVEL Intermediate

FLEX INDEX 70

SIZES 230-235-...-275

SHELL SL

LAST EC 2200cc

Last	100	102	104
Size	24.5	25.5	26.5

COLOR Gray

COMFORT BALANCE

Forward Lean 16°, Ramp Angle 6°



DREAM 80 W

ARTICLE NUMBER

606405

FEATURES

Adjustable wedge arch support
Double canting
Double adjustable profile
Woman-specific supportive heel option, Form Fit

LINER

Women's Perfect Fit HP liner
Fur lining, Self-shaping footbed with Sanitized®, 30 mm velcro strap, Prepared for heating system

BUCKLES

4 micro-adjustable alloy buckles
1 Supermacro ratchet

DETAILS

LEVEL Advanced

FLEX INDEX 80

SIZES 220-225-230-...-275

SHELL SL

LAST WP 1950cc

Last	96	98	100
Size	24.5	25.5	26.5

COLOR Black-white



CUBE3 60 W

ARTICLE NUMBER

606235 White

606239 Black

FEATURES

Integrated autoskiwalk

LINER

Women's Comfort quick entry liner
Sport frame footbed
35 mm velcro strap

BUCKLES

3 micro-adjustable plastic buckles
1 Supermacro ratchet

DETAILS

LEVEL Intermediate

FLEX INDEX 60

SIZES 230-235-...-275

SHELL SL

LAST EC 2200cc

Last	100	102	104
Size	24.5	25.5	26.5

COLOR White

Black

COMFORT BALANCE

Forward Lean 16°, Ramp Angle 6°



RAPTOR 90S RS

ARTICLE NUMBER
607246

FEATURES

Jr racing flex tuning, Jr cuff
Double canting
FIS approved sole thickness
Adult norm

LINER

Jr HeatFit Pro liner
HP frame footbed
40 mm velcro strap

BUCKLES

4 micro-adjustable Spine-Tech alloy buckles, Low profile buckles

DETAILS

LEVEL Professional

FLEX INDEX 90/80

SIZES 220-225-...
-275-280-285

SHELL PU

LAST RS 1800cc

Last	94	96	98
Size	25.5	26.5	27.5

COLOR White

RACE BALANCE

Forward Lean 16°, Ramp Angle 4°



RAPTOR 80 RS

ARTICLE NUMBER
607248

FEATURES

Jr racing flex tuning, Jr cuff
Double canting
FIS approved sole thickness
Adult norm

LINER

Jr HeatFit Pro liner
HP frame footbed
40 mm velcro strap

BUCKLES

4 micro-adjustable alloy buckles
Low profile buckles

DETAILS

LEVEL Expert

FLEX INDEX 80/70

SIZES 220-225-...
-275-280-285

SHELL PU

LAST RS 1800cc

Last	94	96	98
Size	25.5	26.5	27.5

COLOR White

RACE BALANCE

Forward Lean 16°, Ramp Angle 4°

NEW RAPTOR 70

THE RACE BOOT FOR THE NEXT GENERATION OF CHAMPIONS



New Junior Race last are derived from the N°1 Boot on the World Cup, Raptor!

RACE BALANCE
16° Forward Lean
4° Ramp angle

NEW RACING LINER
The perfect blend of performance and fit.



RAPTOR 70

ARTICLE NUMBER
607250

FEATURES

Jr racing flex tuning
Adult norm (size 220 up)

LINER

Junior team liner
Self-shaping footbed
30 mm velcro strap

BUCKLES

4 micro-adjustable alloy buckles
Low profile buckles

DETAILS

LEVEL Expert

FLEX INDEX 70/60

SIZES 200-210-220-...-275

SHELL SL

LAST JR Racing

COLOR White

**RAPTOR 50****ARTICLE NUMBER**

607254

FEATURES

Jr racing flex tuning
Adult norm (size 220 up)

LINER

Junior team liner
Self-shaping footbed
30 mm velcro strap

BUCKLES

4 micro-adjustable low profile
plastic buckles

DETAILS

LEVEL Advanced
FLEX INDEX 50
SIZES 200-210-220-...-275
SHELL SL
LAST JR Racing
COLOR White

**RAPTOR 40****ARTICLE NUMBER**

607261

FEATURES

Adult norm (size 220 up)

LINER

Junior team liner
Self-shaping footbed

BUCKLES

3 Low profile plastic buckles

DETAILS

LEVEL Advanced
FLEX INDEX 40
SIZES 185-190-...-245
SHELL SL
LAST JR Racing
COLOR White

**RAPTOR CADDY 50****ARTICLE NUMBER**

607252

FEATURES

Jr racing flex tuning
Adult norm (size 220 up)

LINER

Junior team liner
Self-shaping footbed
40 mm velcro strap

BUCKLES

4 Low profile plastic buckles

DETAILS

LEVEL Advanced
FLEX INDEX 50
SIZES 200-210-220-...-275
SHELL SL
LAST JR Racing
COLOR Black-white

**RAPTOR CADDY 40****ARTICLE NUMBER**

607260

FEATURES

Adult norm (size 220 up)

LINER

Junior team liner
Self-shaping footbed

BUCKLES

3 Low profile plastic buckles

DETAILS

LEVEL Advanced
FLEX INDEX 40
SIZES 185-190-...-245
SHELL SL
LAST JR Racing
COLOR Black-white





Z KID BOOTS

SKI NATURAL, LEARN FAST!



GEOMETRY

Jr. Hi-top - higher tongue profile and asymmetrical lateral support.

2 PHASE FLEX

Gradual and natural centered balance.

VARIO LAST DESIGN

HEAD's Anatomical last has been developed with respect to the natural growth of kid's feet: Wider last on small sizes.

L = Length
W = Width

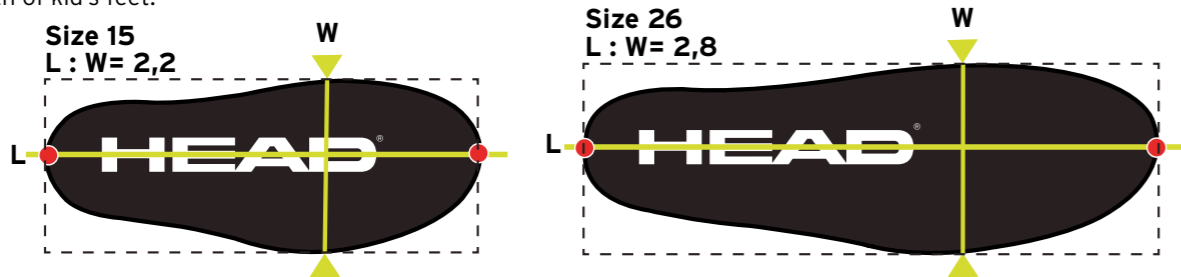

Z3

ARTICLE NUMBER

- 607270 Black-white
- 607271 Yellow-black
- 607272 White
- 607273 White-pink

LINER

Junior liner, Tongue handle, Comfort footbed

BUCKLES

3 plastic buckles

FEATURES

Jr high top tech, Duo flex
Vario last, Easy entry shell construction
Junior norm, Design your boot stickers

DETAILS

LEVEL Intermediate
SIZES 230-235-...-265
SHELL SL
LAST Junior
COLOR Black-white, Yellow-black
White, White-pink



Z2

ARTICLE NUMBER

- 606549 Black-white
- 606551 Yellow-black
- 606552 White
- 606546 White-pink

LINER

Junior liner, Tongue handle, Comfort footbed

BUCKLES

2 plastic buckles

FEATURES

Natural kid stance, Jr high top tech, Duo flex
Vario last, Easy entry shell construction
Junior norm, Design your boot stickers

DETAILS

LEVEL Beginner
SIZES 195-205-215-225
SHELL SL
LAST Junior
COLOR Black-white, Yellow-black
White, White-pink



Z1

ARTICLE NUMBER

- 606561 Black-white
- 606562 Yellow-black
- 606563 White
- 606556 White-pink

LINER

Junior liner, Tongue handle, Comfort footbed

BUCKLES

1 plastic buckle

FEATURES

Natural kid stance, Jr high top tech, Duo flex
Vario last, Easy entry shell construction
Junior norm, Design your boot stickers

DETAILS

LEVEL Beginner
SIZES 155-165-175-185
SHELL SL
LAST Junior
COLOR Black-white, Yellow-black
White, White-pink



BOOT TECHNOLOGY / RAPTOR, VECTOR EVO AND CHALLENGER

SPINEFLEX BUCKLES

Spineflex is a revolutionary buckle concept with a flexible element and a constant closure point. The flexible element allows the buckle to adapt to the shell profile and thus provide a homogeneous foot wrapping

independent from the degree of closure. The increased precision and comfort created from the absence of pressure points results in better performance.

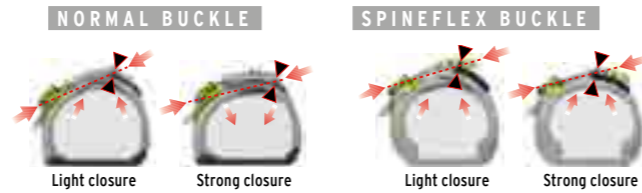

BOOT TECHNOLOGY / VECTOR EVO AND CHALLENGER

DOUBLE POWER SPINEFLEX BUCKLES

Spineflex is a revolutionary buckle concept with a flexible element and a constant closure point. The flexible element allows the buckle to adapt to the shell profile and thus provide a homogeneous foot wrapping independent from the degree of closure.

The increased precision and comfort created from the absence of pressure points results in better performance. The ergonomic, patented Double Power lever increases the leverage of the buckle by 50%, halving the effort required to buckle in. constant release values.



BOOT TECHNOLOGY / CHALLENGER, VECTOR EVO, ADVANT EDGE, EDGE AND CUBE

SUPERMACRO TOOTHPLATE

With a push of a simple button, the ratchet provides a 28 mm range of adjustment granting to fit any leg.

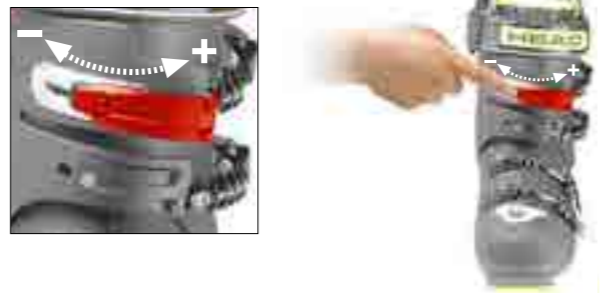

BOOT TECHNOLOGY / CHALLENGER

ADAPTIVE FIT TECHNOLOGY

Adaptive Fit Technology is the first and only ski boot technology that lets you change the width of your boot from a comfort/ performance last to a precision/performance last with the turn of a screw.



BOOT TECHNOLOGY / RAPTOR, VECTOR EVO, CHALLENGER, ADVANT EDGE

DOUBLE POWER BOOSTER VELCRO

The strap of the Double Power Booster Velcro works as a double pulley for better closure and a tighter wrapping on the cuff. The elastic Booster Strap allows more dynamical response of the boot. The result: more precise transmission and faster ski reaction. (Manufactured under license from Skimatrix Ltd.)



Protected under one or more of the following:

European patent N. 1087676,

US patent N. 6.026.594 Canadian patent N. 2.335.698,

Other patents pending.

BOOT TECHNOLOGY / VECTOR EVO

DYNAMIC FRAME SHELL

POWER EFFICIENT DESIGN: BETTER SKIING WITH LESS EFFORT

Modern skiing requires comfort, efficiency, and control. HEAD's new EVO Frame is built around the legendary Vector last, but features a new highly efficient Dynamic frame which directs 80% of the energy directed from the body toward the rear of the shell.

Forefoot area is less subjected to mechanical stresses but needs to provide the feeling on the snow. The Dynamic Frame has been designed to obtain the best sensitivity and the dynamic response of the boot sole when the ski is flexing.

EVO STANCE



BOOT TECHNOLOGY / HAMMER, THRASHER

TRIAD ERGOTECH SHELL

The innovative three piece construction, "Triad Ergotech Shell", provides precision and performance in any terrain and snow condition.

The boots progressive and natural flex is provided by the open throat shell, in addition to the interchangeable tongue and pivot point. The pivot point is placed where the ankle flexes at the rotating point of the shell.

4 CLOSING POINTS

Precise and effective foot retention with maximum performance through improved balance and control.



ERGO STANCE

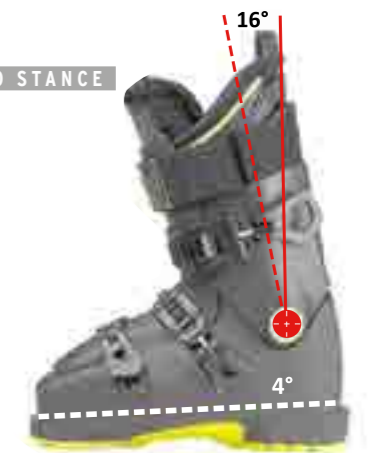

360 FULL CUSHIONING SYSTEM

An innovative system that help to absorb any impact:

- Gel Shin Saver
- Rear spoiler
- Canting
- New toe box material to avoid toe bang
- Footbed and wedge



BOOT TECHNOLOGY / CUBE

EASY AS 1, 2, 3. DEVELOPING OUR CUBE3 LINE, WE DECIDED TO TACKLE THE ONE CHALLENGE EVERY SKIER FACES EVERY DAY ON THE MOUNTAIN: TO COMBINE GREAT SKIING PERFORMANCE WITH GREAT WALKING PERFORMANCE. AFTER ALL, ON ANY GIVEN DAY, WE SPEND UP TO 30% OF OUR TIME OUTSIDE OF THE BINDING.

EASY IN

Thanks to a new quick entry geometry, the Cube3 is extremely easy to get into. Simply tilt back the shaft and step in. In addition, the 3-buckle construction with an oversized top buckle allows easy and quick buckling in and a great, snug fit.



EASY WALK

Outside of the binding, the shaft of the Cube3 is always unlocked, allowing natural walking. This, in combination with (patented) SoftWalk heel and grip system on the heel, makes the Cube a superb walking boot.

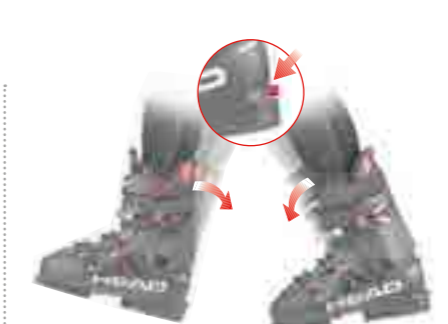

EASY SKI

The moment you step into your binding the patented integrated AutoSkiWalk mechanism blocks the shaft, allowing you to speed off down the mountain without bowing, bending or buckling.





WINTER COLLECTION 2017-18

BINDINGS

HEAD®

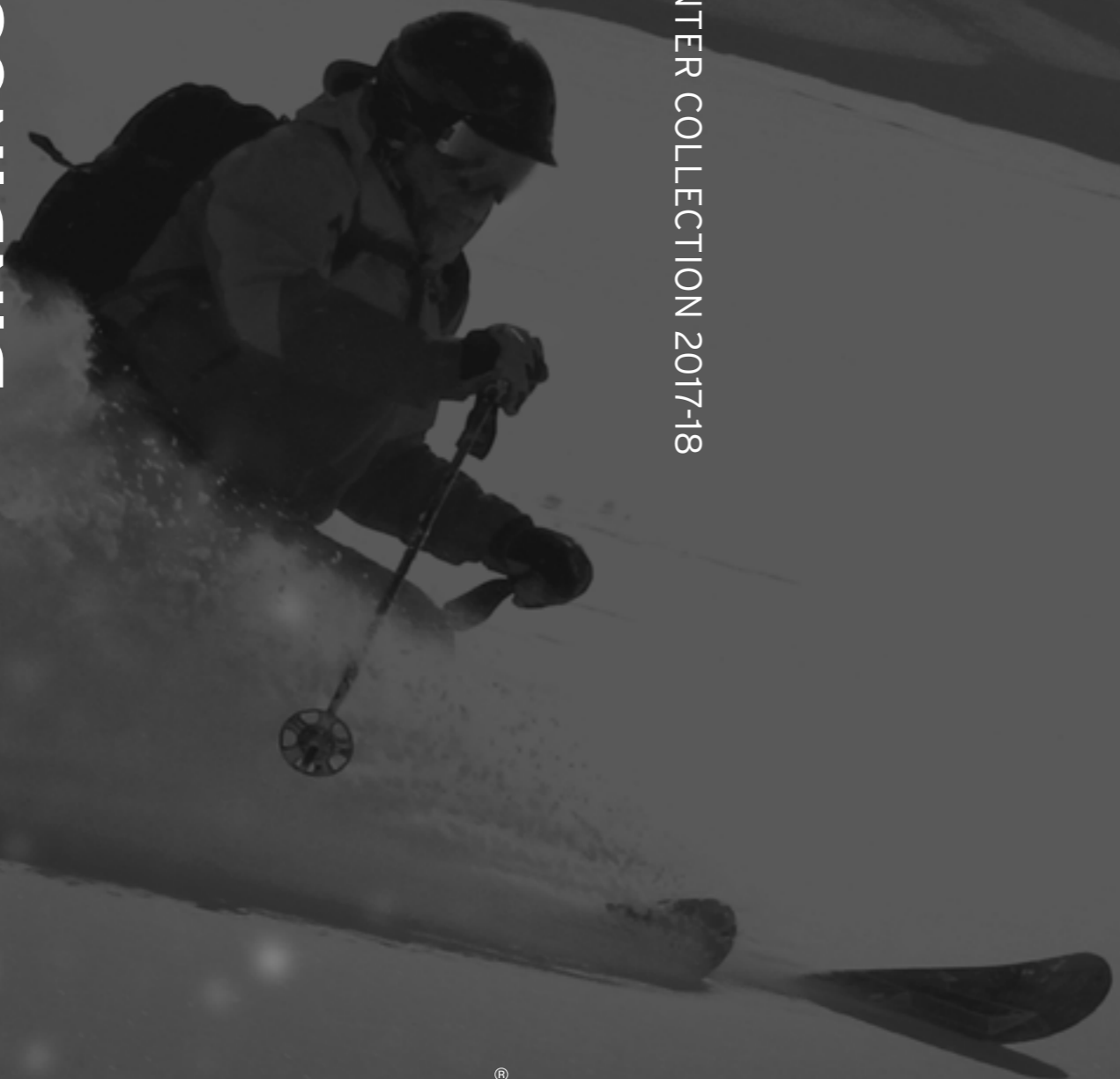



/AAAttack² TECHNOLOGY/

Skiers prefer equipment which provides control, performance and usability. Not only for open slopes and untracked powder areas, also for stoked park and half pipe rides. The TYROLIA AAAttack² reaches the next stage in combining functionality and modern design to meet these demands. A perfect tool for all-around skiers who are willing to attack!



THE NEW FR PRO² TOE

The next level to Access All Areas is reached with the new AAAttack² bindings. A new toe construction extends the possibilities of allmountain skiing: The new standard toe construction in the AAAttack² line - FR PRO² - is compatible with Alpine and GripWalk ski boots. The super secure 77mm metal Anti Friction Device - AFD Metal - can be adjusted to Alpine Boots (Type A ISO 5355) and GripWalk Boots.



GW: suitable for Alpine (A) and GripWalk (GW) Ski Boots

The AAAttack² 14 AT and the AAAttack² DEMO models can be adjusted for Alpine and Touring (T) ski boots, including GripWalk (GW), Walk Sole and Walk To Ride (W) ski boots. With these bindings, boot-binding compatibility issues during demo or in rental become things of the past.



AT: suitable for Alpine (A) and Touring (T) ski boots, including GripWalk (GW), Walk Sole and Walk To Ride (W) ski boots.

Basically, there is an ideal binding model within the AAAttack² line to fit your ski boot. (see p. 88/89)



SAFETY FIRST

To increase the safety and performance aspect of the new AAAttack² bindings, a new release kinematic was developed to reduce friction and guarantee more constant release values. The interaction between the spring and tension element is designed as new system which significantly reduces friction for even more precise and constant release values.

The top models, AAAttack² 18X GW and AAAttack² 16 GW feature the Race Pro Heel with a reduced stand height of only 17mm. The AAAttack² 13 and 12 have the lighter Race Heel. The AAAttack² 11 models feature a modified solid SX Heel construction and reduced weight for optimal allmountain performance.

PERFECT INDIVIDUALITY

These fired up allmountain binding models are available in different DIN settings for different demands. With regards to their clear design and compact measurements, the AAAttack models can be used on skis from 80mm widths onwards. Some models are available without brakes. This gives riders the opportunity to customize the setup to their needs. Brakes are available in different widths: 85/95/110/130/150mm.

Whatever you want - freeski, powder, park, pipe, slope - the tool to access all areas.

ADVANTAGES OF ADJUSTING THE AFD

Adjusting the height of the AFD according to your ski boot sole height has many advantages for your customer and your shop/fleet:

- 1 Exact adaptation of boot-binding system
- 2 Better performance on skis
- 3 Precise release values and re-centering of the boot
- 4 More precise values at the pre-season and in-season inspections and less deficient products

KEEPS YOU BRAVE AAATTACK² BOOT-BINDING-COMPATIBILITY

LINE 2017/18 MODEL	ALPINE - ISO 5355		TOURING - ISO 9523	
	ALPINE ADULT (A)	GRIPWALK (GW)	WALK SOLE / WALK TO RIDE (W)	TOURING (T)
AAATTACK ² 18 X GW	•	•		
AAATTACK ² 16 GW	•	•		
AAATTACK ² 14 AT	•	•	•	•
AAATTACK ² 13 GW	•	•		
AAATTACK ² 12 GW	•	•		
AAATTACK ² 11 GW	•	•		
AAATTACK ² 13 AT DEMO	•	•	•	•
AAATTACK ² 11 AT DEMO	•	•	•	•



FREEFLEX EVO 18 X

The pro level Freeflex Evo 18 X is a premium race binding, tried and tested by our team of World Cup rebels, with pro level safety, performance and unhindered ski flex.

ARTICLE NUMBER	DETAILS
100602 FREEFLEX EVO 18 X	STAND HEIGHT 17 mm
BRAKE 85 [A]	DIN 8-18
	WEIGHT 3170 g
FEATURES	COLORS Black/White/ Flash Yellow
Race Toe with TRP System, Race AFD, Freeflex Pro, Race Pro RD Heel	

FREEFLEX EVO 16

The FIS approved Freeflex Evo 16 dedicated race binding empowers pro level World Cup Rebels with premium safety and performance and minimum ski flex interference.

ARTICLE NUMBER	DETAILS
100655 FREEFLEX EVO 16	STAND HEIGHT 17 mm
BRAKE 85 [A]	DIN 5-16
	WEIGHT 2690 g
FEATURES	COLORS Black/White/ Flash Yellow
Race Toe with TRP System, Race AFD, Freeflex Pro, Race Pro Heel	



FREEFLEX EVO 14

Red hot and delivering premium speed the Freeflex EVO 14 expert level binding provides a fast, reactive ride with premium safety and natural ski flex.

ARTICLE NUMBER	DETAILS
100656 FREEFLEX EVO 14	STAND HEIGHT 21 mm
BRAKE 85 [D]	DIN 4-14
	WEIGHT 2330 g
FEATURES	COLORS Matt Black/White/ Flash Yellow
RX Toe with TRP System, ABS - Anti Blocking System, Full Diagonal, Freeflex Pro, D-RX Heel	



FREEFLEX EVO 11

Delivering confidence and power to beat the clock the race ready Freeflex EVO 11 features top-end safety, lightening reactivity and unhindered ski flex for aspiring race rebels.

ARTICLE NUMBER	DETAILS
100657 FREEFLEX EVO 11	STAND HEIGHT 21 mm
BRAKE 85 [D]	DIN 3-11
	WEIGHT 2260 g
FEATURES	COLORS Matt Black/White/ Flash Yellow
RX Toe with TRP System, ABS - Anti Blocking System, Full Diagonal, Freeflex Pro, Race Lite Heel	

TECHBOX

FREEFLEX EVO

Freeflex EVO reduces the impact on the natural ski flex to a minimum. Decreased forward pressure, completely redesigned roller pincer systems and wings, plus an intelligent gliding element all add up to the rEVolution in racing: fastest time, from the starting gate to the finish line with Freeflex EVO.



AAATTACK² 18 X GW

AAAttack! AAAttack! AAAttack! The compact, rugged and brand new AAAttack² 18 X GW delivers customised aggressive skiing to freeskiers on the attack. For Alpine and GripWalk Ski Boots.

ARTICLE NUMBER	DETAILS
114111 AAATTACK ² 18 X GW w/o BRAKE [A] Red	STAND HEIGHT 17 mm DIN 8-18 WEIGHT 2130g (*2430g) COLOR Red
FEATURES	* with BRAKE
FR PRO ² Toe, AFD Metal, Race Pro FR Heel	

AAATTACK² 16 GW

Compact, supremely versatile with the new FR PRO² toe for Alpine and GripWalk Ski boots and with constant release values the AAAttack² 16 GW is a tough, all-mountain binding for high-end performance from powder and piste to the park and beyond.

ARTICLE NUMBER	DETAILS
114112 AAATTACK ² 16 GW w/o BRAKE [A] Red	STAND HEIGHT 17 mm DIN 5-16 WEIGHT 1940g (*2240g) COLORS Red, Green
114113 AAATTACK ² 16 GW w/o BRAKE [A] Green	
114114 AAATTACK ² 16 GW w/o BRAKE [A] Solid Black	Solid Black
FEATURES	* with BRAKE
FR PRO ² Toe, AFD Metal, Race PRO FR Heel	

AAATTACK² 14 AT

The AAAttack² 14 AT features premium downhill performance with the versatility of the new FR PRO² AT toe that adjusts to alpine (Type A) and touring (Type T) ski boots including GripWalk (GW), Walk Sole and Walk To Ride (W) ski boots.

ARTICLE NUMBER	DETAILS
114115 AAATTACK ² 14 AT w/o BRAKE [A] Solid Black	STAND HEIGHT 24 mm DIN 4-14 WEIGHT 1930g (*2230g) COLOR Solid Black
FEATURES	* with BRAKE
FR PRO ² AT Toe, AFS Metal, NX FR Heel	

AAATTACK² 13 GW

Tough, compact and with precision handling the all-terrain AAAttack² 13 GW is a freeski binding for powerful top notch performance from park transitions to backcountry booters.

ARTICLE NUMBER	DETAILS
114120 AAATTACK ² 13 GW w/o BRAKE [A] Red	114128 AAATTACK ² 13 GW w/o BRAKE [A] Solid Black
114121 AAATTACK ² 13 GW BRAKE 85 [A] Red	114129 AAATTACK ² 13 GW BRAKE 85 [A] Solid Black
114122 AAATTACK ² 13 GW BRAKE 95 [A] Red	114130 AAATTACK ² 13 GW BRAKE 95 [A] Solid Black
114123 AAATTACK ² 13 GW BRAKE 110 [A] Red	114131 AAATTACK ² 13 GW BRAKE 110 [A] Solid Black
114124 AAATTACK ² 13 GW w/o BRAKE [A] Green	FEATURES
114125 AAATTACK ² 13 GW BRAKE 85 [A] Green	FR PRO ² Toe, AFD Metal, NX FR Heel
114126 AAATTACK ² 13 GW BRAKE 95 [A] Green	DETAILS
114127 AAATTACK ² 13 GW BRAKE 110 [A] Green	STAND HEIGHT 17 mm DIN 4-13 WEIGHT 1770g (*2070g) COLORS Red, Green, Solid Black
	* with BRAKE

AAATTACK² 12 GW

The shortcut to aggressive freeskiing for women – the tough, lightweight AAAttack² 12 GW gives premium hold, safety and boot-to-edge power transfer in all zones.

ARTICLE NUMBER	DETAILS
114135 AAATTACK ² 12 GW BRAKE 85 [A] Matt White	STAND HEIGHT 21 mm DIN 3,5-12 WEIGHT 2070g COLOR Matt White
114136 AAATTACK ² 12 GW BRAKE 95 [A] Matt White	
114137 AAATTACK ² 12 GW BRAKE 110 [A] Matt White	FEATURES
	FR PRO ² Toe, AFD Metal, NX FR Heel

AAATTACK² 11 GW

Built to be pushed hard and to push back even harder the AAAttack² 11 is a powerful, safe and stylish freeski binding for allmountain skiers and contemporary trick-savvy freeskiers.

ARTICLE NUMBER	DETAILS
114140 AAATTACK ² 11 GW w/o BRAKE [L] Red	114147 AAATTACK ² 11 GW BRAKE 90 [L] Solid Black
114141 AAATTACK ² 11 GW BRAKE 90 [L] Red	114148 AAATTACK ² 11 GW BRAKE 100 [L] Solid Black
114142 AAATTACK ² 11 GW BRAKE 100 [L] Red	FEATURES
114143 AAATTACK ² 11 GW w/o BRAKE [L] Green	FR PRO ² Toe, AFD Metal, SX FR Heel
114144 AAATTACK ² 11 GW BRAKE 90 [L] Green	DETAILS
114145 AAATTACK ² 11 GW BRAKE 100 [L] Green	STAND HEIGHT 21 mm DIN 3-11 WEIGHT 1550g (*1800g) COLORS Red, Green, Solid Black
114146 AAATTACK ² 11 GW w/o BRAKE [L] Solid Black	* with BRAKE

ATTACK² BOOT-BINDING-COMPATIBILITY

LINE 2017/18 MODEL	ALPINE - ISO 5335		TOURING - ISO 9523	
	ALPINE ADULT (A)	GRIPWALK (GW)	WALK SOLE / WALK TO RIDE (W)	TOURING (T)
AAATTACK ² 18 X GW	•	•		
AAATTACK ² 16 GW	•	•		
AAATTACK ² 14 AT	•	•	•	•
AAATTACK ² 13 GW	•	•		
AAATTACK ² 12 GW	•	•		
AAATTACK ² 11 GW	•	•		
AAATTACK ² 13 AT DEMO	•	•	•	•
AAATTACK ² 11 AT DEMO	•	•	•	•



AT - Alpine Touring.
Suitable for Alpine Boots (ISO 5355), and Touring (ISO 9523) ski boots including GripWalk (GW), Walk Sole and Walk To Ride (W) ski boots.



GW - GripWalk
(Bindings marked with GW fit Alpine and GripWalk Boot Types).

A - Alpine Boot Standard (ISO 5355)
T - Touring Boot Standard (ISO 9523)



AAAMBITION 12 AT

Designed to make alpine touring better the AAAmbition 12 features the benefits of innovative climbing technology, natural ski flex plus proven TYROLIA safety features and downhill performance. For Alpine (ISO 5355) and Touring Ski Boots (ISO 9523).

ARTICLE NUMBER
111610 TYROLIA AAAMBITION 12 AT w/o BRAKE [C] Solid White/Black

FEATURES
AT Toe, AFS, Telescopic Tube, AT Heel

DETAILS
STAND HEIGHT 38 mm (** 41 mm)
DIN 4-12
WEIGHT 1810 g (* 1980 g)
COLOR Solid White/Black

** with Demo Track, * with BRAKE



AAAMBITION 10 AT

The AAAmbition 10 is the key to a supreme touring experience – the ultimate alpine touring binding offering on-the-hoof variable climb technology, natural ski flex and supreme downhill prowess. For Alpine (ISO 5355) and Touring Ski Boots (ISO 9523).

ARTICLE NUMBER
111716 TYROLIA AAAMBITION 10 AT w/o BRAKE [C] Solid White/Black

FEATURES
AT Toe, AFS, Telescopic Tube, AT Heel

DETAILS
STAND HEIGHT 38 mm (** 41 mm)
DIN 3-10
WEIGHT 1790 g (* 1960 g)
COLOR Solid White/Black

** with Demo Track, * with BRAKE



AAAMBITION 12 AT CARBON

Built with a lightweight, strong carbon® profile for less fatigue and performance descents the AAAmbition Carbon is the ultimate AT binding for premium backcountry adventures. For Alpine (ISO 5355) and Touring Ski Boots (ISO 9523).

ARTICLE NUMBER
111710 TYROLIA AAAMBITION 12 AT CARBON S BRAKE 85 [C] Black Carbon
111711 TYROLIA AAAMBITION 12 AT CARBON M BRAKE 85 [C] Black Carbon
111712 TYROLIA AAAMBITION 12 AT CARBON L BRAKE 85 [C] Black Carbon

FEATURES
AT Toe, AFS, Carbon Tube, AT Heel

DETAILS
STAND HEIGHT 38 mm
DIN 4-12
WEIGHT 1620g (*1780g)
COLOR Black Carbon

* with BRAKE

TECHBOX CARBON

LOWER WEIGHT - MORE FUN



What is ideal: a a lower weight or improved safety? This question is a thing of the past when it comes to choosing the perfect touring binding. Tyrolia's AAAMBITION 12 AT CARBON binding combines both desired features by using the high tech material Carbon® in the mid part of the binding. Constant stability at a significantly reduced binding weight (200g) make the Tyrolia AAAmbition Carbon an AT binding with proven downhill performance and safety features. Its benefits of very low weight are highly valued when hiking and touring the back country.

Available in 3 Lengths: SHORT (265-295mm), MEDIUM (295-325mm) and LONG (315-345mm).



AAADRENALIN 16 AT SHORT / LONG

For a stable, versatile freeride experience with direct power transfer choose the AAAdrenalin 16 AT – a revolution in freeski bindings, combining outstanding downhill performance with an ergonomic walking mechanism for short hikes. Fits Alpine (ISO 5355) and Touring Ski Boots (ISO 9523). Short for Boot Sole Lengths from 270-330mm, Long for Boot Sole Lengths from 300-360mm.

ARTICLE NUMBER	DETAILS
114105 TYROLIA AAADRENALIN 16 AT w/o BRAKE [B] short, Solid Black	STAND HEIGHT 38 mm
114106 TYROLIA AAADRENALIN 16 AT w/o BRAKE [B] long, Solid Black	DIN 5-16
	WEIGHT 2440 g
	(* 2740 g) – SHORT
	2460 g
	(*2760 g) – LONG

FEATURES	COLOR
FR PRO Toe, AFS Metal, Hiking Platform, Race Pro FR Heel	Solid Black

* with BRAKE



AAADRENALIN 13 AT SHORT / LONG

The freeride AAAdrenalin 13 AT combines performance driven downhill technology with a fast, convenient ergonomic walking mechanism, for outstanding performance in all zones of the mountain. Fits Alpine (ISO 5355) and Touring Ski Boots (ISO 9523). Short for Boot Sole Lengths from 270-330mm, Long for Boot Sole Lengths from 300-360mm.

ARTICLE NUMBER	DETAILS
114010 TYROLIA AAADRENALIN 13 AT w/o BRAKE [F] SHORT, Solid Black	STAND HEIGHT 39 mm
114011 TYROLIA AAADRENALIN 13 AT w/o BRAKE [F] LONG, Solid Black	DIN 4-13
	WEIGHT 2420 g
	(* 2720 g) – SHORT
	2440 g
	(*2740 g) – LONG

FEATURES	COLORS
FR PRO Toe, AFS Metal, Hiking Platform, NX FR Heel	Solid Black

* with BRAKE



PRD 14

The tough and stable PRD 14 promises better allride performance with less effort - featuring premium safety, easy handling and performance ski control.

ARTICLE NUMBER

100660 PRD 14 BRAKE 85 [F]
Matt black/Grey

FEATURES

RX Toe with TRP System, Full Diagonal, ABS - Anti Blocking System, Suitable for all PR bases, D-RX (Diagonal) Heel

DETAILS

STAND HEIGHT 33,5 mm
DIN 4-14
WEIGHT 2090 g
COLORS Matt Black/Grey



PRD 12

The customisable fit PRD 12 binding, with Supershape colour coordination, provides fast, snappy control with maximum safety and less burn in the turns both on and off piste.

ARTICLE NUMBER

100707 PRD 12 BRAKE 85 [F]
Matt Black/Matt White/fl.Yellow
100708 PRD 12 BRAKE 85 [F]
Matt Black/Matt White/fl. Green
100709 PRD 12 BRAKE 85 [F]
Matt Black/Matt White/fl. Red
100710 PRD 12 BRAKE 85 [F]
Matt Black/Matt White/Light Blue

FEATURES

RX Toe with TRP System, Full Diagonal, ABS - Anti Blocking System, Suitable for all PR bases, D-RX (Diagonal) Heel

DETAILS

STAND HEIGHT 33,5 mm
DIN 3,5-12
WEIGHT 2090 g
COLORS Matt Black/Matt White/fl.Yellow
Matt Black/Matt White/fl. Green
Matt Black/Matt White/fl. Red
Matt Black/Matt White/Light Blue



PR 11

Choose the modular PR11 allride binding delivering supreme all-mountain performance with maximum safety to skiers of all levels and terrain persuasions.

ARTICLE NUMBER

100715 PR 11 Brake 85 [G]
Matt Black/White
100716 PR 11 Brake 78 [G]
Matt Black/Blue/Orange
100717 PR 11 Brake 85 [G]
Matt Black/Flash/Yellow
100718 PR 11 Brake 85 [G]
Matt Black/Red/Green

FEATURES

SX Toe with TRP System, Full Diagonal, AFS - Anti Friction Slider, Suitable for all PR Bases, SX Heel

DETAILS

STAND HEIGHT 31mm
DIN 3-11
WEIGHT 1770 g
COLORS Matt Black/White
Matt Black/Blue/Orange
Matt Black/Flash Yellow
Matt Black/Red/Green



PRD 12 MBS

The mass market innovation combining multiple boot sole compatibility with fast and easy adjustment. Just 2 Positions to fit Alpine (ISO 5355) and GripWalk (GW) boots (Position 1) plus Walk Sole and Walk To Ride (W) ski boots (Position 2).

ARTICLE NUMBER

114157 PRD 12 MBS BRAKE 85 [F]
Solid Black
114158 PRD 12 MBS BRAKE 85 [F]
Matt White/Black
100706 PRD 12 MBS BRAKE 85 [F]
Matt Black/White

DETAILS

STAND HEIGHT 33,5 mm
DIN 3,5-12
WEIGHT 2100 g
COLORS Solid Black
Matt White/Black

FEATURES

AM (Allmountain) Toe with TRP System, Full Diagonal, AFS, Suitable for all PR Bases; D-RX Heel



PR 11 MBS

Multiple boots sole standards (Alpine, GripWalk and Walk Sole/Walk To Ride ski boots) are covered with this performance allmountain binding, combined with fast and easy length adjustability.

ARTICLE NUMBER

114159 PR 11 MBS w/o BRAKE [G]
Solid Black
114160 PR 11 MBS BRAKE 85 [G]
Solid Black
114161 PR 11 MBS BRAKE 85 [G]
Solid White
100713 PR 11 MBS BRAKE 85 [G]
Matt Black/White

FEATURES

AM (Allmountain) Toe with TRP System, Full Diagonal, AFS, Suitable for all PR Bases; SX FR Heel

DETAILS

STAND HEIGHT 31 mm
DIN 3-11
WEIGHT 1580g (*1880g)
COLORS Solid Black
Solid White

* with BRAKE

MBS BOOT BINDING COMPATIBILITY

LINE 2017/18 MODEL	ALPINE - ISO 5355		TOURING - ISO 9523	
	ALPINE ADULT (A)	GRIPWALK (GW)	WALK SOLE/WALK TO RIDE (W)	TOURING (T)
PRD 12 MBS	•	•	•	
PR 11 MBS	•	•	•	

TECHBOX MBS

MBS - MULTI BOOT STANDARD



MBS - the only mass market feature with easy adjustment to different boot sole heights from Alpine & GripWalk to Walk Sole and Walk To Ride ski boots.

Within the 2017.18 PowerRail line, TYROLIA introduces 2 new models with a unique feature for the mass performance segment: MBS - Multi Boot Standard. These models are suitable for Alpine (ISO 5355), GripWalk and Walk Sole/Walk To Ride ski boots.

Adjustment is simple and easy: only two different positions (position 1 - Alpine/GripWalk and position 2 - Walk Sole/Walk To Ride) are marked on the binding toe. Alter the marked position by turning with a screwdriver. No further adjustments or fine tuning with a paper strip are necessary. Done!
The ideal solution for multiple boot sole types, even for busy on-snow demos or rentals!



Position 1
GRIP WALK Alpine, GripWalk (pre-set position)



Position 2
WALK SOLE/WALK TO RIDE Walk Sole/Walk To Ride ski boots



JOY 11 SLR

Undeniably the best women's binding on the mountain, the lightweight, high performance JOY 11 SLR delivers quick edge-to-edge reaction and smooth and agile carving.

ARTICLE NUMBER

100690 JOY 11 SLR
BRAKE 90 [H] White/Teal
100691 JOY 11 SLR
BRAKE 78 [H]
Matt Black/Flash Yellow
100725 JOY 11 SLR
BRAKE 78 [H]
Matt Black/White

DETAILS

STAND HEIGHT 28 mm
DIN 3-11
WEIGHT 1640 g
COLORS
White/Teal
Matt Black/Flash Yellow
Matt Black/White

FEATURES

RX Toe with TRP System,
Full Diagonal,
AFS - Anti Friction Slider,
SuperLiteRail/SuperLiteRail II,
SX Heel

JOY 9 AC SLR

Designed to put the joy into skiing the Joy 9 AC SLR allows supreme fun and performance with half the effort and fatigues.

ARTICLE NUMBER

100726 JOY 9 AC SLR
BRAKE 85 [H] Matt Black/Pink
100694 JOY 9 AC SLR
BRAKE 78 [H] White/Black
100695 JOY 9 AC SLR
BRAKE 90 [H] White/Black
100696 JOY 9 AC SLR
BRAKE 78 [H] Matt Black/Teal

DETAILS

STAND HEIGHT 28 mm
DIN 2,5-9
WEIGHT 1400 g
COLORS
Matt Black/Pink
White/Black
Matt Black/Teal

FEATURES

SX Lite Toe with TRP System,
Full Diagonal,
AFS Jr. - Anti Friction Slider Junior,
SuperLiteRail/SuperLiteRail II,
SX Lite Heel



SLR 7.5 AC (JUNIOR)

Safer, snappier and more precise the lightweight and comfortable SLR 7.5 AC is the best low input, high performance binding on the mountain.

ARTICLE NUMBER

100678 SLR 7.5 AC
BRAKE 78 [H] Solid White/Black/
Flash Yellow
100679 SLR 7.5 AC
BRAKE 78 [H] Solid White/Black

DETAILS

STAND HEIGHT 27 mm
DIN 2-7,5
WEIGHT 1360 g
COLORS
Solid White/Black/Flash Yellow
Solid White/Black

FEATURES

SX Junior Toe with TRP System,
Full Diagonal, AFS Junior,
SuperLiteRail/SuperLiteRail II,
SX Junior Heel

AC = these bindings will fit both adult and children boots

SLR 4.5 AC (JUNIOR)

Designed for performance progression, the light, safe and reliable SLR 4.5 AC delivers fun and confidence to the learning curve of skiing.

ARTICLE NUMBER

100682 SLR 4.5 AC
BRAKE 74 [I] Solid White/Black/
Flash Yellow
100683 SLR 4.5 AC
BRAKE 74 [I] Solid White/Black/

DETAILS

STAND HEIGHT 27 mm
DIN 0,75-4,5
WEIGHT 1250 g
COLORS
Solid White/Black/Flash Yellow
Solid White/Black

FEATURES

SX Kid Toe with TRP System,
Full Diagonal, AFS Junior,
SuperLiteRail/SuperLiteRail II,
SX Kid Heel

AC = these bindings will fit both adult and children boots

TECHBOX

SUPERLITERAIL II - A BINDINGS-BASE SYSTEM BELOW 1700 G!

With the 2-piece SLR II base, weight was reduced significantly. Only 1680 grams per pair (SLR 9.0 AC) makes this system extraordinary light, due to a base weight of only 280 g and a refined lighter binding construction. The benefits: easier turns, less fatigue and more fun on the slopes!

The base offers 4 different mounting positions to cover boot sole lengths between 199 and 347 mm.



EVO 9 AC JR RACE

Light, fast, responsive and fitted with the latest safety technology the EVO 9 AC JR RACE provides junior racers with race winning performance.

ARTICLE NUMBER

100688 EVO 9 AC JR RACE
BRAKE 78 [J] Solid Black/White
Flash Yellow

FEATURES

SX Lite Toe with TRP System,
Full Diagonal, AFS Jr, SX Lite Heel

AC = these bindings will fit both adult and children boots

DETAILS

STAND HEIGHT 21 mm
DIN 2,5-9
WEIGHT 1490 g
COLORS Solid Black/White
Flash Yellow



SX 7.5 AC

Building confidence with stability, direct power transfer and precision ski control - this is the SX 7.5 AC binding for junior skiers who crave progression.

ARTICLE NUMBER

111858 SX 7.5 AC
BRAKE 78 [J] Solid White/Black
114180 SX 7.5 AC
BRAKE 78 [J] Solid Black/White
114083 SX 7.5 AC
BRAKE 90 [J] Solid Black/White

FEATURES

SX Junior Toe with TRP System,
Full Diagonal, AFS Junior,
SX Junior Heel

AC = these bindings will fit both adult and children boots

DETAILS

STAND HEIGHT 21 mm
DIN 2-7,5
WEIGHT 1400 g
COLORS Solid White/Black
Solid Black/White
Solid Black/White



SX 4.5 AC

The safe, performance driven SX 4.5 AC is the encouragement and confidence that aspiring young champions of speed need to succeed.

ARTICLE NUMBER

111554 SX 4.5 AC
BRAKE 74 [K] Solid Black/Silver
111555 SX 4.5 AC
BRAKE 74 [K] Silver/Black
111557 SX 4.5 AC
BRAKE 74 [K] Solid White/Black

FEATURES

SX Kid Toe with TRP System, Full
Diagonal, AFS Junior, SX Kid Heel

AC = these bindings will fit both adult and children boots

DETAILS

STAND HEIGHT 15 mm
DIN 0,75- 4,5
WEIGHT 1190 g
COLORS Solid Black/Silver
Silver/Black
Solid White/Black

BINDINGS SET-ALTERNATIVES / OVERVIEW

SKI ART.N.	NAME	BINDING ART.N.	BINDING NAME	BINDING COLORS
PERFORMANCE				
310287	Supershape I.Titan SW MFPR	100710	PRD 12 BRAKE 85 [F]	matt black/matt white/light blue
		100660	PRD 14 BRAKE 85 [F]	solid black
		100706	PRD 12 MBS BRAKE 85 [F]	matt black/grey
310347	Supershape I.Rally SW MFPR	100709	PRD 12 BRAKE 85 [F]	matt black/matt white/fl. red
		100660	PRD 14 BRAKE 85 [F]	solid black
		100706	PRD 12 MBS BRAKE 85 [F]	matt black/grey
310307	Supershape I.Magnum SW MFPR	100708	PRD 12 BRAKE 85 [F]	matt black/matt white/fl. green
		100660	PRD 14 BRAKE 85 [F]	solid black
		100706	PRD 12 MBS BRAKE 85 [F]	matt black/grey
310327	Supershape I.Speed SW MFPR	100707	PRD 12 BRAKE 85 [F]	matt black/matt white/fl. yellow
		100660	PRD 14 BRAKE 85 [F]	solid black
		100706	PRD 12 MBS BRAKE 85 [F]	matt black/grey
310606	Prestige SW TFB carry over	100660	PRD 14 BRAKE 85 [F]	matt black/grey
		100706	PRD 12 MBS BRAKE 85 [F]	solid black
310626	Premium SW TFB carry over	100660	PRD 14 BRAKE 85 [F]	matt black/grey
		100706	PRD 12 MBS BRAKE 85 [F]	solid black
ALLRIDE				
310807	MONSTER 108 TI SW	104105	AAADRENALIN 16 AT SHORT w/o BRAKE [B]	solid black
		104106	AAADRENALIN 16 AT LONG w/o BRAKE [B]	solid black
		104114	AAATTACK*16 GW w/o BRAKE [A]	solid black
		104113	AAATTACK*16 GW w/o BRAKE [A]	green
		104127	AAATTACK*13 GW BRAKE 110 [A]	green
		104131	AAATTACK*13 GW BRAKE 95 [A]	solid black
310827	MONSTER 98 TI SW	104115	AAATTACK*14 AT w/o BRAKE [A]	solid black
		104105	AAADRENALIN 16 AT SHORT w/o BRAKE [B]	solid black
		104106	AAADRENALIN 16 AT LONG w/o BRAKE [B]	solid black
		104131	AAATTACK*13 GW BRAKE 110 [A]	solid black
310847	MONSTER 88 TI SW	104122	AAATTACK*13 GW BRAKE 95 [A]	red
		104130	AAATTACK*13 GW BRAKE 95 [A]	solid black
		104114	AAATTACK*16 GW w/o BRAKE [A]	solid black
		104112	AAATTACK*16 GW w/o BRAKE [A]	red
		104115	AAATTACK*14 AT w/o BRAKE [A]	solid black
310867	MONSTER 83 TI SW	104129	AAATTACK*13 GW BRAKE 85 [A]	solid black
		104114	AAATTACK*16 GW w/o BRAKE [A]	solid black
		104115	AAATTACK*14 AT w/o BRAKE [A]	solid black
310907	Power INSTINCT SW Ti Pro AB	104160	PR 11 MBS BRAKE 85 [G]	solid black
		100718	PR 11 BRAKE 85 [G]	matt black/red/green
		100709	PRD 12 BRAKE 85 [F]	matt black/matt white/fl. red
		100713	PR 11 MBS BRAKE 85 [G]	matt black/white
310947	Raw INSTINCT SW Ti Pro AB	104160	PR 11 MBS BRAKE 85 [G]	solid black
		100718	PR 11 BRAKE 85 [G]	matt black/red/green
		100708	PRD 12 BRAKE 85 [F]	matt black/matt white/fl. green
		100713	PR 11 MBS BRAKE 85 [G]	matt black/white
310967	Strong INSTINCT Ti AB	100717	PR 11 BRAKE 85 [G]	matt black/flash yellow
		104160	PR 11 MBS BRAKE 85 [G]	solid black
		100707	PRD 12 BRAKE 85 [F]	matt black/matt white/fl. yellow
		100713	PR 11 MBS BRAKE 85 [G]	matt black/white
310987	Supreme INSTINCT Ti AB	100716	PR 11 BRAKE 78 [G]	matt black/blue/orange
		104159	PR 11 MBS W/O BRAKE [G]	solid black
		100713	PR 11 MBS BRAKE 85 [G]	matt black/white
311007	Natural INSTINCT AB	100716	PR 11 BRAKE 78 [G]	matt black/blue/orange
		104159	PR 11 MBS W/O BRAKE [G]	solid black
		100713	PR 11 MBS BRAKE 85 [G]	matt black/white
311107	Primal INSTINCT AB	100715	PR 11 BRAKE 85 [G]	matt black/white
		104160	PR 11 MBS BRAKE 85 [G]	solid black
		100713	PR 11 MBS BRAKE 85 [G]	matt black/white
311127	Primal INSTINCT PP9	104135	SX 10 BRAKE 18 [LJ]	silver/black
		100713	PR 11 MBS BRAKE 85 [G]	matt black/white
FREETSKI				
Big Mountain				
311407	Kore 117	104113	AAATTACK*16 GW W/O BRAKE [A]	green
		104105	AAADRENALIN 16 AT SHORT w/o BRAKE [B]	solid black
		104106	AAADRENALIN 16 AT LONG w/o BRAKE [B]	solid black
		104124	AAATTACK*13 GW W/O BRAKE [A]	green
311427	Kore 105	104113	AAATTACK*16 GW W/O BRAKE [A]	green
		104105	AAADRENALIN 16 AT SHORT w/o BRAKE [B]	solid black
		104106	AAADRENALIN 16 AT LONG w/o BRAKE [B]	solid black
		104115	AAATTACK*14 AT w/o BRAKE [A]	solid black
		104127	AAATTACK*13 GW BRAKE 110 [A]	green
311447	Kore 93	104126	AAATTACK*13 GW BRAKE 95 [A]	green
		104115	AAATTACK*14 AT w/o BRAKE [A]	solid black
		104101	AAADRENALIN 13 AT SHORT w/o BRAKE [F]	solid black
		104011	AAADRENALIN 13 AT LONG w/o BRAKE [F]	solid black
All Country				
310757	Nebula 78	101716	AAAMBITION 10 AT w/o BRAKE [C]	solid white/black
		101610	AAAMBITION 12 AT w/o BRAKE [C]	solid white/black
310797	Alpine Walker	101716	AAAMBITION 10 AT w/o BRAKE [C]	solid white/black
Park&Pipe				
311507	Frame Wall	104129	AAATTACK*13 GW BRAKE 85 [A]	solid black
		104114	AAATTACK*16 w/o BRAKE [A]	solid black
		104147	AAATTACK*11 GW BRAKE 90 [L]	solid black
311527	Caddy	104121	AAATTACK*13 GW BRAKE 85 [A]	red
		104111	AAATTACK*18 X GW w/o BRAKE [A]	red
		104112	AAATTACK*16 GW w/o BRAKE [A]	red
		104141	AAATTACK*11 GW BRAKE 90 [L]	red
311547	the Show	104129	AAATTACK*13 GW BRAKE 85 [A]	solid black
		104125	AAATTACK*13 GW BRAKE 85 [A]	green
		104144	AAATTACK*11 GW BRAKE 90 [L]	green
WOMEN				
311647	great Joy	104137	AAATTACK*12 GW BRAKE 110 [A]	matt white
311667	wild Joy	104136	AAATTACK*12 GW BRAKE 95 [A]	matt white
311627	total Joy SLR	100690	JOY 11 SLR BRAKE 90 [H]	white/teal
311607	super Joy SLR	100691	JOY 11 SLR BRAKE 78 [H]	matt black/flash yellow
311677	epic Joy SLR	100725	JOY 11 SLR BRAKE 78 [H]	matt black/white
311687	absolut Joy SLR	100695	JOY 9 AC SLR BRAKE 78 [H]	white/black
311707	pure Joy SLR	100696	JOY 9 AC SLR BRAKE 78 [H]	matt black/real
311727	easy Joy SLR2	100726	JOY 9 AC SLR BRAKE 85 [H]	matt black/pink
JUNIOR				
319877	SG 200 Race Plate RDX	100602	FREFLEX EVO 18 X BRAKE 85 [A]	black/white/flash yellow
319887	SG 195 Race Plate RDX	100602	FREFLEX EVO 18 X BRAKE 85 [A]	black/white/flash yellow
319897	SG 185 Race Plate RDX	100602	FREFLEX EVO 18 X BRAKE 85 [A]	black/white/flash yellow
319907	SG 175 JRP RDX	100602	FREFLEX EVO 18 X BRAKE 85 [A]	black/white/flash yellow
314007	WC Rebels i.GS RD Team SW JRP RDX 173	100656	FREFLEX EVO 14 BRAKE 85 [D]	matt black/white/flash yellow
	WC Rebels i.GS RD Team SW JRP RDX 166	100656	FREFLEX EVO 14 BRAKE 85 [D]	matt black/white/flash yellow
	WC Rebels i.GS RD Team SW JRP RDX 159	100657	FREFLEX EVO 11 BRAKE 85 [D]	matt black/white/flash yellow
	WC Rebels i.GS RD Team SW JRP RDX 152	100657	FREFLEX EVO 11 BRAKE 85 [D]	matt black/white/flash yellow
	WC Rebels i.GS RD Team SW JRP RDX 145	100688	EVO 9 AC JR RACE Brake 78 [J]	solid black/flash yellow
	WC Rebels i.GS RD Team SW JRP RDX 138	100688	EVO 9 AC JR RACE Brake 78 [J]	solid black/flash yellow
	WC Rebels i.GS RD Team SW JRP RDX 124	100688	EVO 9 AC JR RACE Brake 78 [J]	solid black/flash yellow
314027	WC Rebels i.SL RD Team SW JRP RDX 156	100656	FREFLEX EVO 14 BRAKE 85 [D]	matt black/white/flash yellow
	WC Rebels i.SL RD Team SW JRP RDX 150	100657	FREFLEX EVO 11 BRAKE 85 [D]	matt black/white/flash yellow
	WC Rebels i.SL RD Team SW JRP RDX 144	100657	FREFLEX EVO 11 BRAKE 85 [D]	matt black/white/flash yellow
	WC Rebels i.SL RD Team SW JRP RDX 138	100657	FREFLEX EVO 11 BRAKE 85 [D]	matt black/white/flash yellow
	WC Rebels i.SL RD Team SW JRP RDX 132	100657	FREFLEX EVO 11 BRAKE 85 [D]	matt black/white/flash yellow
	WC Rebels i.SL RD Team SW JRP RDX 126	100688	EVO 9 AC JR RACE Brake 78 [J]	solid black/flash yellow
	WC Rebels i.SL RD Team SW JRP RDX 120	100688	EVO 9 AC JR RACE Brake 78 [J]	solid black/flash yellow
314147	WC iRace Team SW SLR2	100678	SLR 7.5 AC BRAKE 78 [H]	solid white/black/flash yellow
314187	Supershape SLR2	100678	SLR 7.5 AC BRAKE 78 [H]	solid white/black/flash yellow
314237	Supershape Team SLR 2: 67-107cm	100682	SLR 4.5 AC BRAKE 74 [I]	solid white/black/flash yellow
	Supershape Team SLR 2: 117-157cm	100678	SLR 7.5 AC BRAKE 78 [H]	solid white/black/flash yellow
314067	Caddy Jr	104083	SX 7.5 AC BRAKE 90 [J]	solid black/white
		104141	AAATTACK*11 GW BRAKE 90 [L]	red
		100679	SLR 7.5 AC BRAKE 78 [H]	solid white/black
314177	Residue SLR2	100683	SLR 4.5 AC BRAKE 74 [I]	solid white/black
314247	Joy SLR 2: 67-107cm	100679	SLR 7.5 AC BRAKE 78 [H]	solid white/black
	Joy SLR 2: 117-147cm	100679	SLR 7.5 AC BRAKE 78 [H]	solid white/black
314287	Monster SLR 2: 67-107cm	100682	SLR 4.5 AC BRAKE 74 [I]	solid white/black/flash yellow
	Monster SLR 2: 117-157cm	100678	SLR 7.5 AC BRAKE 78 [H]	solid white/black/flash yellow
314307	Souphead SLR2	100683	SLR 4.5 AC BRAKE 74 [I]	solid white/black
		100679	SLR 7.5 AC BRAKE 78 [H]	solid white/black



AMBITION

THE TOURING BINDING

The TYROLIA AAAmbition Alpine Touring binding is the perfect companion for all Alpine Touring Aficionados so that no terrain remains unattainable. We included every attribute of our high-performance alpine ski bindings in this Alpine Touring binding.

ALPINE TOURING TOE

This Alpine Touring Binding features the exclusive TYROLIA Alpine Touring (AT) Toe which can be easily adjusted to alpine and touring boot norms. A 65 mm wide mechanical AFS gliding element secures constant release values also with rubber soles. In combination with two rollers this binding provides superior safety features with the rapid and exact boot re-centering that skiers expect from TYROLIA. As a result of its harmonious design, the TYROLIA AAAmbition has a wider contact area which improves stability and provides a secure foundation for every skiing situation. Furthermore, its pivot is efficiently positioned right below the ski boot tip to ensure perfect force transmission and a tilt up to 90 degrees.



EASY ADJUSTABLE TELESCOPIC TUBE

Additionally the AAAmbition features a unique light-weight telescopic tube which offers an easy adjustment opportunity to different boot sole lengths. Thus, with only one binding model it is possible to cover the entire range of different sole lengths - from 260mm up to 350mm. Furthermore, with the setting of the telescopic tube and through the compact mounting, perfect binding positioning on your skis is improved and mid-point deviation is avoided.



TYROLIA FREEFLEX

The TYROLIA approved Freeflex System, which interacts with the AT Toe, the telescopic tube and the AT Heel, offers natural dynamics, excellent downhill performance and therefore a supreme ski touring experience.

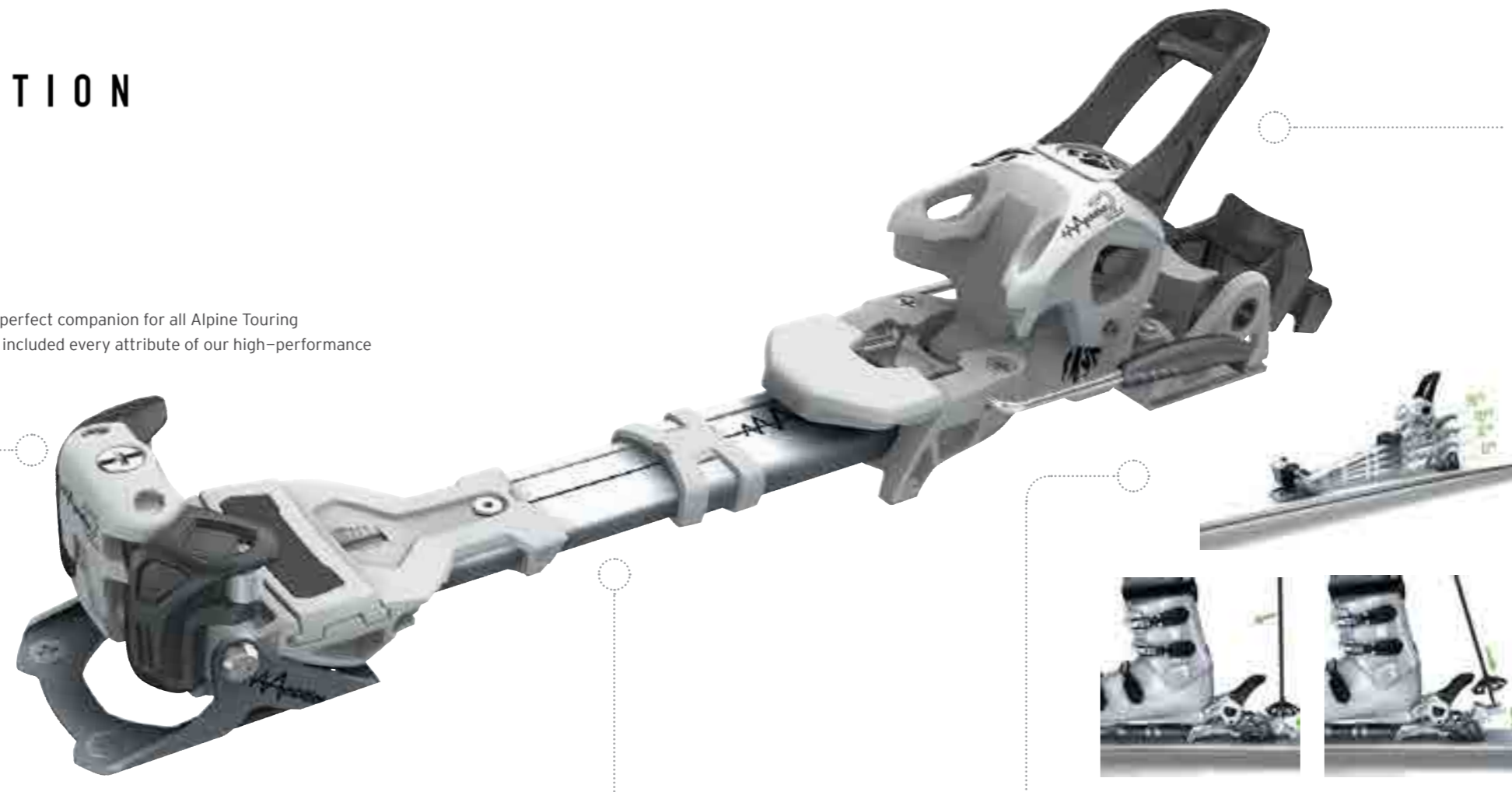

ALPINE TOURING HEEL AND CLIMBING AID

The state-of-the-art designed climbing aid is positioned as close as possible to the Alpine Touring (AT) Heel. This provides better walking balance and effortless climbing in all situations. The low stand height of 38 mm improves stability and offers a confident stance. With four different climbing aid positions (climbing in a 0°, 5°, 10° or 15° position) it is possible to adapt on different terrains without stepping out of the binding. It does not matter if it is a walk through flat terrain or a steep slope up to the summit. Simply use the ski pole in order to change the climbing aid position and also to lock for the downhill ride.

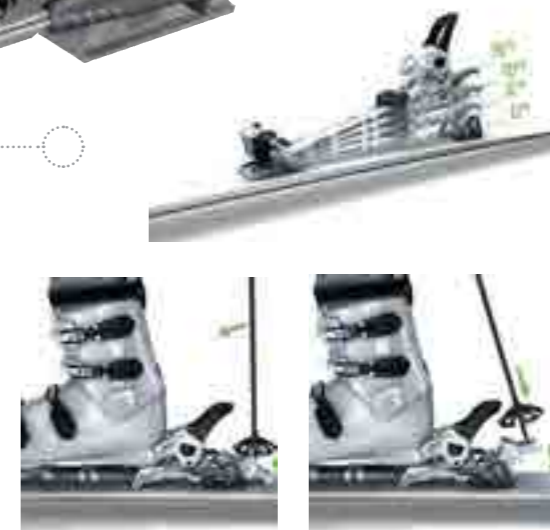

CRAMPONS

Additional crampons are available as spare parts in widths of 90 mm, 105 mm and 120 mm, and provide safe climbing and a secure stand in any situation.

- 90 mm: A. No.: 163006 (1 pair)
- 105 mm: A. No.: 163007 (1 pair)
- 120 mm: A. No.: 163008 (1 pair)

DEMO AND RENTAL SUITABLE

In order to offer ambitious sportsmen an opportunity to widen their horizons, the TYROLIA AAAmbition is also demo and rental suitable: Combined with a spare demo track, the TYROLIA AAAmbition Alpine Touring binding can be tested and shown to a broad audience. Only two easy adjustments (one on the telescopic tube and one on the demo track) are required to fit to different boot lengths without extra drilling. A. No: 163001



BRAKES & INDIVIDUALITY

Considering the different ski widths, the TYROLIA AAAmbition comes without brakes. This gives you the opportunity to either choose the perfect fitting brake out of four different widths (85 mm/95 mm/105 mm/125 mm) or simply to ride and hike without brakes using appropriate powder straps - TYROLIA AAA-Series Powder Strap (1 pair): A. No.: 162981. Additionally available: TYROLIA AAA-Series Powdercord - A.No.: 163025



To sum up: The TYROLIA AAAmbition Alpine Touring binding is what every ski touring fanatic was looking for. On one hand it offers freedom and individual adjustment possibilities and on the other hand it provides the premium high-end performance that is expected from the world market leader TYROLIA. The solid, light-weight construction and its maximum functionality enhances the ultimate mountain experience for ambitious climbers as well as for touring newbies. Overcome boundaries - Simply just: Access All Areas!



DRENALIN

THE PERFECT ALL-AROUNDER

With the AAAadrenalin Freeride binding from TYROLIA, no terrain is out of reach. This binding provides a level of skiing performance never before seen in an alpine binding. It combines performance driven freeride features with the ultimate ergonomic walking mechanism for maximum freedom on- and off-piste. Overcome boundaries smoothly for a perfect ride.

The TYROLIA AAAadrenalin binding is a perfect option for freeriders who prefer precise downhill control combined with ideal mechanics for short walks to reach untouched paths for a memorable ski experience. Designed together with freeskiers and backcountry skiers, this member of the TYROLIA AAA-Series is designed for ski widths from 80 mm and wider. The TYROLIA AAAadrenalin brings paramount freeride performance in every terrain, on every slope.

FREERIDE (FR) PRO TOE

The TYROLIA AAAadrenalin comes with the Freeride (FR) Pro Toe with its ergonomic pivot position for optimal tilt up movement up to 90 degrees. This system provides effortless walking over short distances.

The FR Pro Toe is adjustable by changing the position of the Anti-Friction-Slider (AFS Metal) to cover alpine and touring boot norms. This 68 mm wide slider plus a stainless steel gliding element provide constant release values and result in a broader contact area to the ski boot sole.

The benefits: more stability, more direct power transmission and an ultimate skiing performance.



← 60mm →

FREERIDE (FR) PRO HEEL

The ultra-wide 80 mm heel track makes all the performance difference needed to take this product over the top. Extra width and the superior kinematics of TYROLIA's high performance bindings make it absolutely stable and reliable for perfect force transmission and unmatched performance. The heel can easily be adjusted to different boot sole lengths without any additional tools.

It covers a wide range of seven ski boot sizes. The TYROLIA AAAadrenalin Freeride binding is available in two lengths:

- SHORT (S) for ski boot sole length of 270–330 mm
- LONG (L) for ski boot sole length of 300–360 mm



← 60mm →



AAA-ASCENDER LOCK AND CLIMBING AID

To Access All Areas, transition from skiing to hiking is incredibly fast, easy and convenient. Simply use the tip of the ski pole without stepping out of the binding to move the highly visible Ascender Lock to change between hiking and ski mode.

Another TYROLIA feature is the possibility to walk in the 0° position. After release, TYROLIA's climbing aid can easily be operated with a ski pole and it can be positioned in three different angles (0°, 7° and 13°) for an optimal walking position. This improves balance and a secure stand on your way to perfect skiing spots.

CRAMPONS

Additionally, TYROLIA crampons (available as spare parts in three widths: 90 mm, 105 mm and 120 mm) can be mounted to improve grip in steep and icy terrain.

- 90 mm: A. No.: 162977 (1 pair)
- 105 mm: A. No.: 162978 (1 pair)
- 120 mm: A. No.: 162979 (1 pair)



Whether skiing downhill or bridging walking paths, the TYROLIA AAAadrenalin Freeride binding gives adventures an unrivaled combination of skiing performance and all terrain versatility, providing easy Access to All Areas!

FREEFLEX

The platform of TYROLIA's AAAadrenalin binding provides the approved TYROLIA Freeflex function which allows the ski to flex as it is designed to do so it can retain its natural dynamics. Freeflex is enabled by the free gliding plate that runs within the titanal heel track and is supported by the center of rotation of the binding toe.



BRAKES & INDIVIDUALITY

The TYROLIA AAAadrenalin comes without brakes. This gives each freeriders the chance to choose the precisely fitting brakes with regard to the ski widths. The TYROLIA AAAadrenalin bindings can be combined with brake widths of 85/95/110/130 [F] or 95/110/130 [B]



Additionally available:
TYROLIA AAA-Series Powdercord – Art. No.:163025





PROTECTION

WINTER COLLECTION 2017-18



HEAD[®]



SAFETY

Our helmets fulfill highest safety standards for ski & snowboard helmets, taking into account the results of collision tests to ascertain qualities of puncture resistant dampening and puncture. This is why some of the world's best athletes are trusting our products.

FIT

The perfect fit of a helmet is vital to fulfill its protective purpose. To assure a perfect fit, we teamed up with BOA. Their accurate size adjustment system combined with HEAD's liner technology adapts the helmet's fit to individual head shapes. For a comfortable fit and a maximum level of protection.



COMFORT

The soft material of our liners adapts perfectly to the head and thus avoids any bruises and the unpleasant entering of cold air. Molded-in mesh zones let heat and moisture escape to the outside and, together with the ventilation system, ensure a comfortable head climate. The innovative Cantilever feature ensures a wrinkle-free size adjustment, adding extra comfort and increased fit.

HELMETS TECHNOLOGY

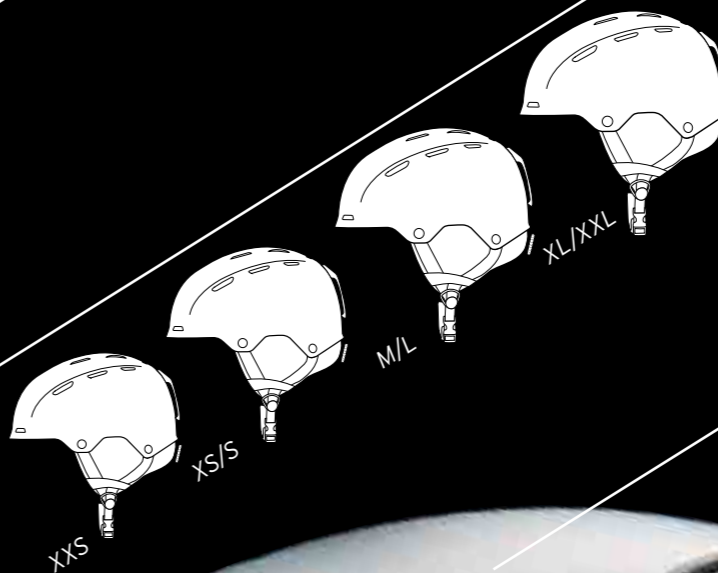

4 SIZES

The all-new T-Series comes in four sizes, all featuring their own specific shell mold. This is especially important on smaller sizes, where weight and fit is crucial to assure the protective qualities of a helmet.





STIVOT RACE CARBON

Helmet of choice for our World Cup Rebels

ARTICLE NUMBER

320017 black/lime
320027 white/black
320037 Rebels



FEATURES

Hardshell technology, Carbon, Metal Chinstrap Buckle, Thermal Ventilation, Beanie Liner, Neckgator, Chinguard compatible

SIZES

XS	S	M
53-54 cm	55-56 cm	57-58 cm
L	XL	XXL
59-60 cm	60-61 cm	61-62 cm

Certification:
CE EN 1077:2007 Class A,
ASTM F 2040,
FIS RH 2013 conform

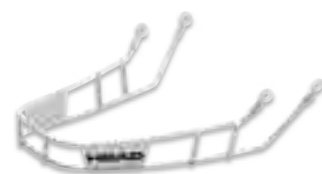
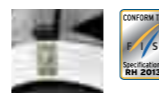

STIVOT RACE CHINGUARD

Compatible with all STIVOT RACE CARBON helmets

ARTICLE NUMBER

376103 SLALOM RACING CHINGUARD

FEATURES

Compatible with all STIVOT RACE CARBON helmets

SIZES XS/S, M/L, XL/XXL



STIVOT

Full shell helmet for recreational downhill speedsters

ARTICLE NUMBER

320206 black/white
320216 white/lime
320227 Rebels



FEATURES

Hardshell technology, Thermal Ventilation, Beanie Liner, Neckgator, Chinguard compatible

SIZES

XS	S	M
52-53 cm	54-55 cm	56-57 cm
L	XL	XXL
58-59 cm	60-61 cm	62-63 cm

Certification:
CE EN 1077:2007 Class A, ASTM F 2040



TEAM SL + CHINGUARD

Half-shell head protection with Chinguard. The helmet of choice in technical disciplines.

ARTICLE NUMBER

320407 black/lime
320417 white/black
320427 Rebels



FEATURES

Hardshell technology, Thermal Ventilation, Beanie Liner, Head 2D Fit, Neckgator, Cantilever, Chinguard included

SIZES	XS/S	M/L
	52-55 cm	56-59 cm
	XL/XXL	
	60-63 cm	

Certification:
CE EN 1077:2007 Class B



TUCKER BOA

An all-mountain high-performance helmet with an urban aesthetic

ARTICLE NUMBER

324747 black
324757 black/lime
324767 apple



FEATURES

Hardshell technology, Thermal Ventilation, Beanie Liner, Neckgator, Cantilever, Removable Earpads/Neckgator, BOA 360°

SIZES

XS/S	M/L	XL/XXL
52-55 cm	56-59 cm	60-63 cm

Certification: CE EN 1077:2007 Class B



TREX

Maximum protection and comfort with minimum impact on the wallet

ARTICLE NUMBER

324837 black
324847 white
324857 olive
324877 blue



FEATURES

Hardshell technology, Thermal Ventilation, Beanie Liner, Cantilever, Removable Earpads, HEAD 3D Fit

SIZES

XS/S	M/L	XL/XXL
52-55 cm	56-59 cm	60-63 cm

Certification: CE EN 1077:2007 Class B





KNIGHT PRO

Ultimate head protection with integrated visor styling

ARTICLE NUMBER

324027 nightblue
324037 white

FEATURES

In-Mold technology, Visor Construction, Lower Microshell, Thermal Ventilation, Microfleece, Beanie Liner, Neckgator, Head 2D Fit

Visors: Smoke/Silver Cat. S3 (VLT 12%), Orange/Silver Cat. S2 (VLT 20%)

SIZES

XS/S	M/L	XL/XXL
50-54 cm	54-57 cm	58-61 cm

Certification: CE EN 1077:2007 Class B



VARIUS BOA

The perfect head protection for steaming groomers and getting fly

ARTICLE NUMBER

324207 black

FEATURES

In-Mold technology, Adjustable Ventilation, Active Bottom Edge, Venturi Effect, Microfleece, Beanie Liner, Neckgator, Removable Earpads/Neckgator, BOA 270° Fit

SIZES

XS/S	M/L	XL/XXL
52-55 cm	56-59 cm	60-63 cm

Certification: CE EN 1077:2007 Class B



KNIGHT

Perfect fit helmet with stylish integrated visor

ARTICLE NUMBER

324107 black
324117 blue

FEATURES

In-Mold technology, Visor Construction, Lower Microshell, Thermal Ventilation, Microfleece, Beanie Liner, Neckgator, Head 2D Fit

Visors: Orange/Silver Cat. S2 (VLT 20%)

SIZES

XS/S	M/L	XL/XXL
50-54 cm	54-57 cm	58-61 cm

Certification: CE EN 1077:2007 Class B



VARIUS

Adjustable Ventilation and protection both on and off-piste

ARTICLE NUMBER

324317 black
324347 anthracite

FEATURES

In-Mold technology, Adjustable Ventilation, Active Bottom Edge, Venturi Effect, Microfleece, Beanie Liner, Neckgator, Removable Earpads/Neckgator, HEAD 3D Fit

SIZES

XS/S	M/L	XL/XXL
52-55 cm	56-59 cm	60-63 cm

Certification: CE EN 1077:2007 Class B



VICO

All-mountain head protection for all-out rippers

ARTICLE NUMBER

324557 black
324567 blue

FEATURES

In-Mold technology, Venturi Effect, Beanie Liner, Neckgator, Removable Earpads/Neckgator, HEAD 3D Fit

SIZES

XS/S	M/L	XL/XXL
52-55 cm	56-59 cm	60-63 cm

Certification: CE EN 1077:2007 Class B

TECHBOX VISOR

HEAD Visor Construction is a wind-sealed UV protective shield that allows skiers to ride wearing prescription glasses. Like on a motorcycle helmet the visor can be pulled down to protect the eyes while riding.

As for goggles, Visors are available in different categories, depending on the according weather conditions: S3 for bright and sunny days, S2 for changing conditions and S1 for cloudy or snowy days.



THEA BOA

Performance all-mountain women's helmet with an urban edge

ARTICLE NUMBER

325407 white
325417 coral



FEATURES

Hardshell technology, Thermal Ventilation, Beanie Liner, Neckgator, Cantilever, Removable Earpads/Nackgator, BOA 360°

SIZES

	XS/S	M/L
	52-55 cm	56-59 cm

Certification: CE EN 1077:2007 Class B



VANDA BOA

The perfect head protection for steaming groomers and getting fly

ARTICLE NUMBER

325107 white

FEATURES

In-Mold technology, Adjustable Ventilation, Active Bottom Edge, Venturi Effect, Microfur, Beanie Liner, Neckgator, Removable Earpads/Nackgator, BOA 270° Fit

SIZES

	XS/S	M/L
	52-55 cm	56-59 cm

Certification: CE EN 1077:2007 Class B



TINA

Tough ABS Hardshell technology for tough girls

ARTICLE NUMBER

325707 white
325717 black
325727 grey



FEATURES

Hardshell technology, Thermal Ventilation, Beanie Liner, Cantilever, Removable Earpads, HEAD 3D Fit

SIZES

	XS/S	M/L
	52-55 cm	56-59 cm

Certification: CE EN 1077:2007 Class B



VANDA

Adjustable Ventilation and protection both on and off-piste

ARTICLE NUMBER

325207 white
325217 turquoise

FEATURES

In-Mold technology, Adjustable Ventilation, Active Bottom Edge, Venturi Effect, Microfur, Beanie Liner, Neckgator, Removable Earpads/Nackgator, HEAD 3D Fit

SIZES

	XS/S	M/L
	52-55 cm	56-59 cm

Certification: CE EN 1077:2007 Class B



QUEEN

Maximum protection and integrated visor for women

ARTICLE NUMBER

325007 white
325017 turquoise



FEATURES

In-Mold technology, Visor Construction, Lower Microshell, Thermal Ventilation, Microfur, Beanie Liner, Neckgator, Head 2D Fit

Visor: Orange/Silver Cat. S2 (VLT 20%)

SIZES

	XS/S	M/L
	50-54 cm	54-57 cm

Certification: CE EN 1077:2007 Class B



VALERY

All-mountain head protection

ARTICLE NUMBER

325607 white
325617 purple

FEATURES

In-Mold technology, Venturi Effect, Microfur, Beanie Liner, Neckgator, Removable Earpads/Nackgator, HEAD 3D Fit

SIZES

	XS/S	M/L
	52-55 cm	56-59 cm

Certification: CE EN 1077:2007 Class B



TAYLOR

The little guy's helmet that is big on safety and tech

ARTICLE NUMBER

- 328207 Rebels
- 328217 red
- 328227 sun
- 328237 blue



FEATURES

Hardshell technology,
Thermal Ventilation, HEAD 3D Fit
Comfort Zone Liner

SIZES

XXS	XS/S	M/L
48-51 cm	52-55 cm	56-59

Certification: CE EN 1077:2007 Class B



JOKER

Grom helmet with all the protection and comfort of the adult line

ARTICLE NUMBER

- 328616 black
- 328626 blue
- 328636 lime



FEATURES

In-Mold technology, Thermal Ventilation,
Comfort Zone Liner, Head 2D Fit

SIZES

XXS/XS	S/M
49-52 cm	53-56 cm

CE EN 1077:2007 Class B, ASTM F 2040



STAR

Girls helmet with all the protection and comfort of the adult line

ARTICLE NUMBER

- 328716 white
- 328726 lightblue



FEATURES

In-Mold technology, Thermal Ventilation,
Comfort Zone Liner, Head 2D Fit

SIZES

XXS/XS	S/M
49-52 cm	53-56 cm

CE EN 1077:2007 Class B, ASTM F 2040





GOGGLES

WINTER COLLECTION 2017-18



HEAD[®]

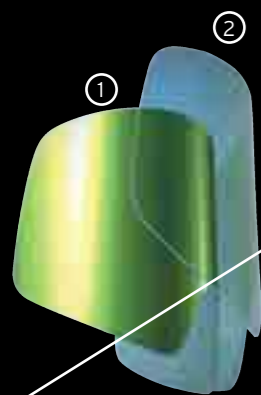

SCRATCH RESISTANT
 TVT lenses are highly scratch resistant. This is achieved by applying the mirror coating ① on the inside of the contrast enhancing TVT polycarbonate lens ②.

TVT TECHNOLOGY
 PERFECT VISION. FOR LONGER

LENSE SHAPES

CYLINDRICAL
 The Cylindrical Lens is a flat lens with a single lateral curve that provides a superior field of vision. It also looks great!

TORIC
 Toric lenses are curved in a way which avoids optical distortion, for the most accurate vision.

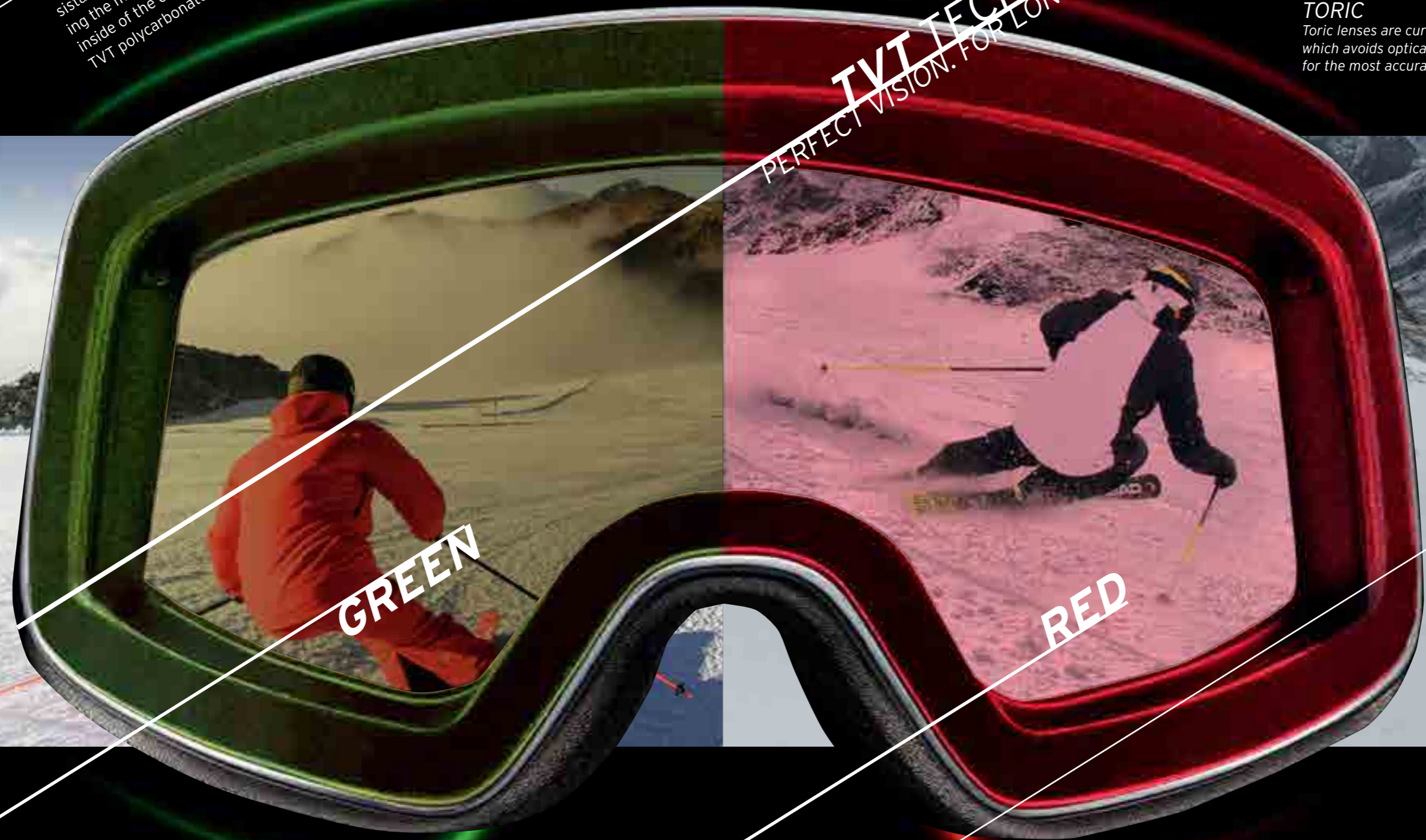

GREEN

RED

RELAX

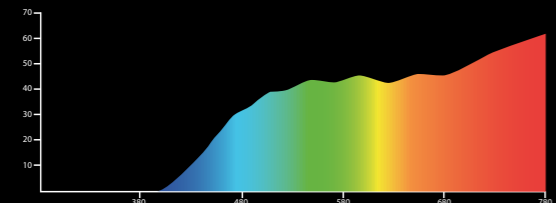
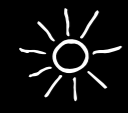

Green lens tints have a harmonizing, regenerating effect on our mood. Compared to other lens colors, green is less affecting our visual perception, but helping to increase our vision especially in bright light conditions, as it homogeneously tones down the visible light spectrum.

This makes it the perfect option for a relaxed day on snow.

ACTION

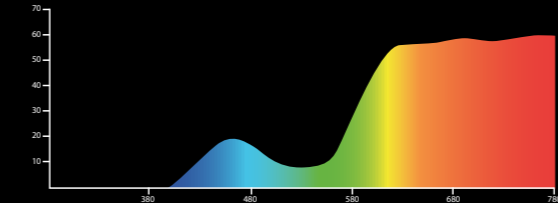

Red lenses help to focus on the essentials when in action. The red lens tint mainly blocks the blue frequencies of the visible light spectrum, focusing on the yellow and red spectral areas. In snowy surroundings, this is resulting in an increased perception of contrast.

The red lens tint is the perfect choice when the action is on.

CONFIGURATOR

1. SHAPE

Cylindrical vs. toric, bold vs. slim - selecting the right shape is important for proper function and look of your goggle.

FUNCTION

Packed with features for high demand and regular use. Quick lens exchange system, triple layer form and lots of spare lens options.

HORIZON



GLOBE



FASHION

Contemporary goggle design for recreational skiers and riders. Lots of style meets everyday comfort.

INFINITY



GALACTIC



BUDGET

For the occasional winter sports enthusiast. Featuring everything you need for the days on snow, so why pay for more.

STREAM



SOLAR



2. VISION

Changing weather situations demand for a variety of lens tones - perfect vision for every condition.

S3

Bright and sunny conditions require a dimming lens tone.

SMOKE

Bluebird? The dimming smoke lens is your choice.

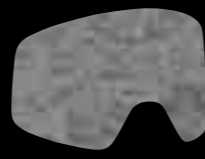

GREEN

For bright & sunny conditions when some additional contrast is needed.



S2

Versatile lens for changeable weather conditions.

BROWN

Brown lenses are the most versatile lenses for every condition.



TVT green

TVT is HEAD's take on contrast enhancing lense technology

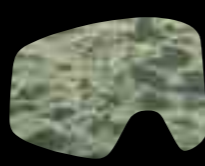

TVT red

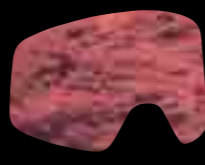

S1

For cloudy or snowy days on the mountain.

ORANGE

Orange lenses are perfect for over-cast conditions.



3. COATING

From a basic stylish black to a flashy mirror coating. We got you covered for the right style when hitting the slopes.

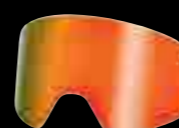
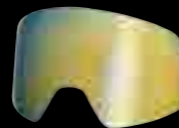
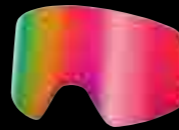
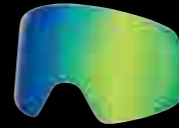

HORIZON RACE

Team tested race goggle with extremely wide field of vision

ARTICLE NUMBER

- 373305 DH lime* + SpareLens
- 373314 black +SpareLens
- 373324 lime + SpareLens
- 373335 white + SpareLens

FEATURES

Wind Seal Foam, Double Lens, Speed Snap Lens Exchange, UV400 & Anti Fog, Triple Layer Foam, Extreme Wide Field of Vision, Silicone Layer, compatible with all HEAD helmets, Sparelens included

LENS	S2, VLT 27%
SPARELENS	S1, VLT 57%

INFINITY RACE

Mid size lens race goggle

ARTICLE NUMBER

- 372006 black +SpareLens
- 372016 white +SpareLens
- 372026 lime +SpareLens

FEATURES

Double Lens, Mirror Coated, Interchangeable Lens, UV400 & Anti Fog, Double Layer Foam, Silicone Layer, compatible with all HEAD helmets, Sparelens included

LENS	S2, VLT 27%
SPARELENS	S1, VLT 57%

HORIZON LENS KIT

Lens kit to beat changing light conditions

ARTICLE NUMBER	373947
CLEAR:	S0 / 86%
YELLOW:	S1 / 82%
ORANGE:	S2 / 21%
BLUE FMR:	S3 / 10%

STRAP KIT

STRAP KIT for customizing race goggles



ARTICLE NUMBER	373965
Compatible with all HEAD goggles	

COLOR

Red, Green, Blue, Silver, Gold

GLOBE series

The **GLOBE** is a brand new goggle with a big, bold toric lens design. This double lens offers top-of-the-line UV protection and anti-fogging qualities, while its frameless construction creates a modern outline that is perfectly helmet compatible. The goggle's Speed Snap Lens Exchange system allows lenses to be swapped on the go and new TVT lens technology delivers enhanced contrast and improved scratch resistance.



GLOBE TVT

ARTICLE NUMBER

390107 TVT red

390117 TVT green

FEATURES

Double Lens, Toric Lens

Speed Snap Lens Exchange

UV400 & Anti Fog, Triple Layer Foam

Extreme Wide Field of Vision

Silicone Layer

compatible with all HEAD helmets

LENS TVT red: S2, VLT 21%

TVT green: S2, VLT 23%

BIG, BOLD GOGGLE WITH CONTRAST ENHANCING TECHNOLOGY



GLOBE FMR (SPARELENS)

Bold goggle for bigger faces with additional cloudy conditions lens

ARTICLE NUMBER

390207 FMR + SpareLens silver

390217 FMR + SpareLens gold

FEATURES

Double Lens, Toric Lens

Speed Snap Lens Exchange

UV400 & Anti Fog, Triple Layer Foam

Extreme Wide Field of Vision

Silicone Layer

compatible with all HEAD helmets

LENS FMR silver: S3, VLT 12%

FMR gold: S2, VLT 24%

SPARELENS orange: S1, VLT 57%

GLOBE FMR

Big goggle for unrestricted field of vision and a bold look

ARTICLE NUMBER

390307 FMR blue/green

390317 FMR gold

390327 FMR yellow/red

390337 FMR silver

FEATURES

Double Lens, Toric Lens

Speed Snap Lens Exchange

UV400 & Anti Fog, Triple Layer Foam

Extreme Wide Field of Vision

Silicone Layer

compatible with all HEAD helmets

LENS FMR blue/green: S3, VLT 11%

FMR gold: S2, VLT 24%

FMR yellow/red: S2, VLT 32%

FMR silver: S3, VLT 12%



GLOBE

Unrestricted field of vision that doesn't cost the earth

ARTICLE NUMBER

390407 black

390417 orange

FEATURES

Double Lens, Toric Lens

Speed Snap Lens Exchange

UV400 & Anti Fog, Triple Layer Foam

Extreme Wide Field of Vision

Silicone Layer

compatible with all HEAD helmets

LENS black: S3, VLT 17%

orange: S1, VLT 60%

HORIZON series

The **HORIZON TVT** is a co-creation of HEAD and their professional athletes. It delivers supreme comfort, unmatched eye protection, function and cutting edge style in all winter sports environment. Features include ultimate UV and anti-fogging, a very wide field of vision, Speed Snap Lens Exchange system, helmet compatibility and slip-free silicone strap backing. They also possess the new contrast enhancing and scratch resistant TVT lens technology.



HORIZON TVT

ARTICLE NUMBER

391107 red TVT

391117 green TVT

FEATURES

Double Lens, Mirror Coated
 Speed Snap Lens Exchange
 UV400 & Anti Fog, Triple Layer Foam
 Extreme Wide Field of Vision
 Silicone Layer
 compatible with all HEAD helmets

LENS TVT red: S2, VLT 21%

TVT green: S2, VLT 23%

THE GOGGLE OF CHOICE FOR HEAD ATHLETES
 WITH CONTRAST ENHANCING TECHNOLOGY



HORIZON FMR (SPARELENS)

Classic all-mountain goggle with additional cloudy conditions lens

ARTICLE NUMBER

391207 FMR + SpareLens silver

391217 FMR + SpareLens yellow/red

FEATURES

Double Lens, Mirror Coated
 Speed Snap Lens Exchange,
 UV400 & Anti Fog, Triple Layer Foam
 Extreme Wide Field of Vision
 Silicone Layer
 compatible with all HEAD helmets
 Sparelens included

LENS FMR silver: S3, VLT 9%

FMR yellow/red: S2, VLT 28%

SPARELENS orange: S1, VLT 57%



HORIZON FMR

Team look goggles with super wide field of vision

ARTICLE NUMBER

391307 FMR blue/green

391317 FMR gold

391327 FMR pink

391337 FMR silver

FEATURES

Double Lens, Mirror Coated
 Speed Snap Lens Exchange,
 UV400 & Anti Fog, Triple Layer Foam
 Extreme Wide Field of Vision
 Silicone Layer
 compatible with all HEAD helmets

LENS FMR blue/green: S3, VLT 9%

FMR gold: S3, VLT 16%

FMR pink: S3, VLT 12%

FMR silver: S3, VLT 9%



HORIZON

Perfect fit, optimum comfort and unrestricted field of vision

ARTICLE NUMBER

391407 black

391417 orange

391427 Rebels

FEATURES

Double Lens, Mirror Coated
 Speed Snap Lens Exchange
 UV400 & Anti Fog, Triple Layer Foam
 Extreme Wide Field of Vision
 Silicone Layer
 compatible with all HEAD helmets

LENS black: S3, VLT 11%

orange: S1, VLT 58%

MR silver: S2, 27%

GALACTIC series

The **GALACTIC** features a mid size frameless toric lens design, with a double lens for top-of-the-line UV protection and anti-fogging qualities. They also have dual density face foam with microfleece for supreme comfort and contouring and our brand new contrast enhancing and scratch resistant TVT lens technology.



GALACTIC TVT

ARTICLE NUMBER

392107 red TVT

392117 green TVT

FEATURES

Double Lens, Toric Lens

UV400 & Anti Fog

Double Layer Foam

Silicone Layer

compatible with all HEAD helmets

LENS TVT red: S2, VLT 21%

TVT green: S2, VLT 23%

MID SIZE GOGGLE WITH
CONTRAST ENHANCING TECHNOLOGY



GALACTIC FMR (SPARELENS)

Toric goggle for medium faces with additional lens for cloudy conditions

ARTICLE NUMBER

392207 FMR + SpareLens gold

392217 FMR + SpareLens silver

FEATURES

Double Lens, Toric Lens

UV400 & Anti Fog, Double Layer Foam

Silicone Layer

compatible with all HEAD helmets

Sparelens included

LENS FMR gold: S2, VLT 24%

FMR silver: S3, VLT 12%

SPARELENS orange: S1, VLT 57%



GALACTIC FMR

Mid size goggle with contemporary frameless lens construction

ARTICLE NUMBER

392307 FMR blue/green

392317 FMR silver

392327 FMR yellow/red

392337 FMR pink

FEATURES

Double Lens, Toric Lens

UV400 & Anti Fog, Double Layer Foam

Silicone Layer

compatible with all HEAD helmets

LENS FMR blue/green: S3, VLT 11%

FMR silver: S3, VLT 12%

FMR yellow/red: S2, VLT 28%

FMR pink: S3, VLT 14%



GALACTIC

Toric goggle for medium size faces for all weather conditions

ARTICLE NUMBER

392407 black

392417 orange

FEATURES

Double Lens, Toric Lens

UV400 & Anti Fog, Double Layer Foam

Silicone Layer

compatible with all HEAD helmets

LENS black: S3, VLT 17%

orange: S1, VLT 60%

INFINITY series

The **INFINITY TVT** combines on-the-button styling with maximum eye protection in a mid size lens. The cylindrical construction mirrored double lens offers supreme UV protective and anti-fogging as well as a superior field of vision. Add to this supreme comfort, our new contrast enhancing and scratch resistant TVT lens technology plus top face fit and hold and you have a goggle that stays clear in all conditions.



INFINITY TVT

ARTICLE NUMBER

393107 red TVT

393117 green TVT

FEATURES

Double Lens
UV400 & Anti Fog
Double Layer Foam
Silicone Layer
compatible with all HEAD helmets

LENS TVT red: S2, VLT 21%

TVT green: S2, VLT 23%



INFINITY FMR (SPARELENS)

Clean, frameless medium size goggle with additional cloudy conditions lens

ARTICLE NUMBER

393207 FMR + SpareLens blue/green

393217 FMR + SpareLens pink

FEATURES

Double Lens, UV400 & Anti Fog
Double Layer Foam, Silicone Layer
compatible with all HEAD helmets
Sparelens included

LENS FMR blue/green: S3, VLT 8%

FMR pink: S3, VLT 12%

SPARELENS orange: S1, VLT 57%



INFINITY FMR

Cylindrical goggle with a frameless profile

ARTICLE NUMBER

393307 FMR silver

393317 FMR yellow/red

393327 FMR pink

393337 FMR silver/red

FEATURES

Double Lens, UV400 & Anti Fog
Double Layer Foam, Silicone Layer
compatible with all HEAD helmets

LENS FMR silver: S3, VLT 9%

FMR yellow/red: S2, VLT 28%

FMR pink: S3, VLT 12%

FMR silver: S3, VLT 9%



INFINITY

Mid size entry-level goggle for all weather conditions

ARTICLE NUMBER

393407 black

393417 orange

FEATURES

Double Lens, UV400 & Anti Fog
Double Layer Foam, Silicone Layer
compatible with all HEAD helmets

LENS black: S3, VLT 11%

orange: S1, VLT 58%

MODERN GOGGLE WITH CONTRAST ENHANCING TECHNOLOGY FOR MEDIUM SIZE FACES



SOLAR FMR

Bargain award winning goggle featuring everything you need

ARTICLE NUMBER

394407 black
394417 FMR lime
394427 FMR blue
394437 FMR red

FEATURES

Double Lens
Toric Lens, UV400 & Anti Fog
Comfort Foam

LENS	black: S3, VLT 17%
	FMR lime: S3, VLT 13%
	FMR blue: S3, VLT 15%
	FMR red: S2, 26%



SOLAR FMR PACK

Pre packed goggle set, containing 8 goggles in two frame sizes (4 M, 4 L). Including a shop counter display.

ARTICLE NUMBER
394607

SOLAR STORM PACK

Pre packed goggle set, containing 8 goggles in two frame sizes (4 M, 4 L). Including a shop counter display.

ARTICLE NUMBER
394617



SOLAR

Award winning goggle for cloudy weather conditions

ARTICLE NUMBER

394447 orange
394457 yellow

FEATURES

Double Lens, Toric Lens
UV400 & Anti Fog
Comfort Foam

LENS	orange: S1, VLT 57%
	yellow: S1, VLT 68%



STREAM

Entry-level goggle with premium UV protection

ARTICLE NUMBER

394707 black
394717 orange

FEATURES

Double Lens, UV400 & Anti Fog
Comfort Foam
compatible with all HEAD helmets

LENS	black: S3, VLT 11%
	orange: S1, VLT 58%



NINJA

Kids' helmet compatible goggle with premium protection

ARTICLE NUMBER

373725 black/green
373735 white/pink
373806 lime/black
394817 Rebels

FEATURES

Spherical Double Lens
UV400 & Anti Fog
Comfort Foam
compatible with all HEAD Junior helmets

LENS	orange: S1, 60%
------	-----------------



SOLAR ISPO AWARD

Why pay for features you don't need? The SOLAR is a new seasonal goggle concept - featuring everything a goggle needs, looks awesome & is easy on the budget. Superlight, toric polycarbonate double-lens, lens ventilation, multi colored mirror, ergonomically molded comfort foam, helmet compatible and exchangeable straps. Available as single pack or pre-packed in a box of 8 including a POS counter display - a whole new market approach. This is why the SOLAR was awarded as WINNER 2016 by the ISPO jury.



**ISPO AWARD
WINNER**
2016/2017



BODY PROTECTION

WINTER COLLECTION 2017-18

BODY PROTECTION TECHNOLOGY

WE GOT YOUR BACK!
FULL ACTION REQUIRES FULL PROTECTION. NOT LIMITING FREEDOM OF MOVEMENT, OUR PROTECTORS INCREASE THE SAFETY WHEN HITTING THE SLOPES.

FEATURES

REMOVABLE PROTECTION UNIT

The Protection Unit can be removed from the parent garment for ease of washing.

REMOVABLE SHOULDER STRAPS

Removable Shoulder Straps can be easily removed and reattached to comply with FIS regulations.

ADJUSTABLE CONNECTOR STRAPS

Adjustable trouser connector straps

EXTRA WIDE WAIST BELT

The height adjustable waist belt measures 120mm in width and delivers a secure, comfortable fit.

MATERIAL

SAS TEC VISCOELASTIC FOAM

Viscoelastic Foam is a soft, conformable, shock absorbent, temperature resistant material with a 10-year guaranteed lifespan; it also can take repeated beatings and still keep protecting.

POLYGIENE®

Polygiene® permanent odor control technology is based on silver salt made from recycled silver. It neutralizes odor by stopping the growth of bacteria on the fabric, so you can wear more and wash less.

THERMO FLEECE

Thermo Fleece delivers warmth, wicks moisture, doesn't restrict movement, has a soft inner and durable, anti-pile treated exterior; tough, yet cosy.

3D MESH

3D Mesh is a three-dimensional fabric that allowing optimal air circulation between fabric and skin.

FLATLOCK SEAMS

High elasticity and tensile strength make Nylon 6 a good choice for applications where toughness, impact resistance and durability are critical.

FITTING

FLEXOR JACKET/VEST/UNIT UNISEX/MEN				
SIZE	HT/CM	HT/INCH	1/CM	1/INCH
S	163	64,2	41	16
M	170	66,9	43	16,7
L	175	68,9	44	17,2
XL	188	74	47	18,5
XXL	212	83,5	53	20,9

FLEXOR VEST/UNIT WOMEN				
SIZE	HT/CM	HT/INCH	1/CM	1/INCH
XS	155	61	44	17,4
S	163	64,2	47	18,3
M	170	66,9	49	19,1
L	175	68,9	50	19,7

FLEXOR JACKET/VEST JUNIOR				
SIZE	HT/CM	HT/INCH	1/CM	1/INCH
116	130	51,2	37	14,6
128	140	55,1	40	15,7
140	150	59,1	43	16,9
152	160	63	46	18
164	175	68,9	50	19,7

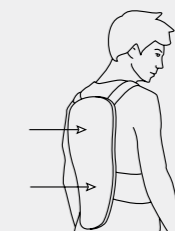
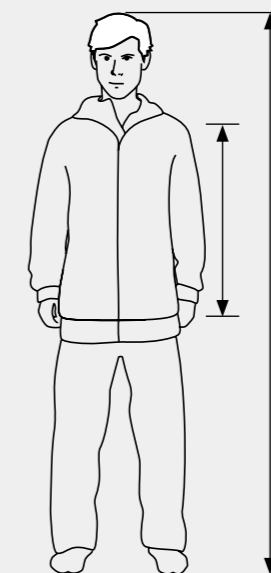

BACK PROTECTOR
A back protector may only provide you with full protection if you have chosen the correct size and adjusted it to your body.

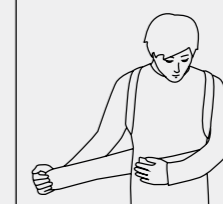

ADJUST THE PROTECTOR
Apply the protector and tighten the straps. The protector shall sit tight against the body without limiting the freedom of movement.

FLEXOR VEST

Integrated impact back protection with freedom of movement

ARTICLE NUMBER

395214

FEATURES

SAS TEC Viscoelastic Foam
Removable Protection Unit
Extra Wide Waist Belt
Flatlock Seams
3D Mesh
Polygiene®

SIZES S - XXL



FLEXOR VEST WOMAN

Comfort, warmth and back protection in one vest

ARTICLE NUMBER

395614

FEATURES

SAS TEC Viscoelastic Foam, Removable Protection Unit, Extra Wide Waist Belt, Flatlock Seams, Thermo Fleece, 3D Mesh, Polygiene®

SIZES XS - L

FLEXOR JR VEST

Comfort, warmth and back protection in a junior vest

ARTICLE NUMBER

395714

FEATURES

SAS TEC Viscoelastic Foam, Removable Protection Unit, Extra Wide Waist Belt, Flatlock Seams, 3D Mesh, Polygiene®

SIZES 116, 128, 140, 152, 164



FLEXOR UNIT RACE

FIS approved back protection

ARTICLE NUMBER

395314

FEATURES

SAS TEC Viscoelastic Foam
Removable Protection Unit
Extra Wide Waist Belt
Removable Shoulder Straps
3D Mesh
Polygiene®

SIZES S - XXL



FLEXOR UNIT

FIS approved ergonomic back protection

ARTICLE NUMBER

395324

FEATURES

SAS TEC Viscoelastic Foam
Removable Protection Unit
Extra Wide Waist Belt
Removable Shoulder Straps
3D Mesh,
Polygiene®

SIZES S - XXL



FLEXOR JR UNIT RACE

FIS approved race back protection with improved freedom of movement

ARTICLE NUMBER

395824

FEATURES

SAS TEC Viscoelastic Foam, Removable Protection Unit, Removable Shoulder Straps, 3D Mesh, Polygiene®

SIZES 116, 128, 140, 152, 164



FLEXOR JR UNIT

FIS compatible back protection for junior racers

ARTICLE NUMBER

395814

FEATURES

SAS TEC Viscoelastic Foam, Removable Protection Unit, Removable Shoulder Straps, 3D Mesh, Polygiene®

SIZES 116, 128, 140, 152, 164

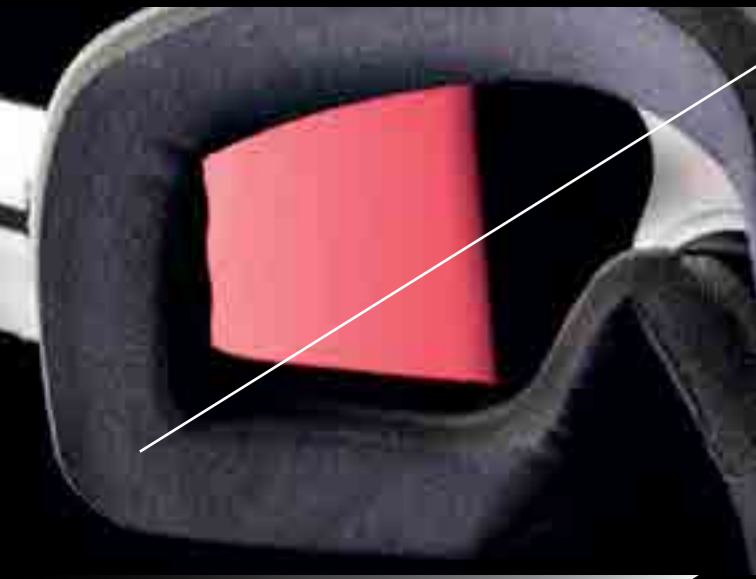

COMFORT

Dual-density Comfort Foam with Microfleece is a bonded foam with a soft fleece for added comfort. The two foams serve different purposes, including anti-fogging, climate regulation and padding while the fleece creates the ideal comfort layer between goggle and skin.

SPEED SNAP LENS EXCHANGE

Speed Snap Lens Exchange is a fast and easy lens exchange system. Lenses snap in and out quickly and easily allowing a rider to keep up with the changing light conditions.



GOGGLES TECHNOLOGY

TRANS VISION TECHNOLOGY TVT

TVT is a contrast enhancing technology for variable weather conditions. TVT lenses are also highly scratch resistant.



PERFECT LOOK, PERFECT SIGHT.
INNOVATION IS IN OUR DNA - WE DESIGN PRODUCTS THAT MEET THE HIGH STANDARDS OF OUR ATHLETES. RICH IN FEATURES, DESIGNED RIGHT DOWN TO THE DETAIL.

FEATURES

EXTREME WIDE FIELD OF VISION

Head's goggles with an extra wide field of vision are perfect for athletes allowing a tight aerodynamic tuck position without impaired vision.

SPARELENS INCLUDED

Sparelens included

SPEED SNAP LENS EXCHANGE

Speed Snap Lens Exchange is a fast and easy lens exchange system.

INTERCHANGEABLE LENSES

Interchangeable Lenses means that they can be changed to suit light conditions or when damaged.

FRAMELENS

The Framelens is a sub-frame construction that holds the lens that can be changed using the Speed Snap System.

LENS

DOUBLE LENS

Outside break resistant hardcoated PC-lens, inside Acetate lens with antifog coating

TORIC LENS

Toric lenses are curved in a way which avoids optical distortion.

CYLINDRICAL LENS

The Cylindrical Lens is a flat lens with a single lateral curve.

UV400 & ANTI FOG

UV400 & Anti Fog refers to the intense UV protective qualities of HEAD lenses and their ability to minimise fogging.

FILTER CATEGORY

Filter Category describes the specific light filtering of lenses.

TRANS VISION TECHNOLOGY (TVT)

TVT is a contrast enhancing technology for variable weather conditions. TVT lenses are also highly scratch resistant.

FMR

FMR is HEAD's flashy multi-layer mirror finish to their lenses providing added protection against sunlight.

MR

MR is HEAD's single mirror finish to their lenses providing added protection against sunlight.

MATERIAL

WINDSEAL FOAM

Windseal Foam is a wind retardant foam.

VENTING FOAM

Venting Foam allows the transfer of air, heat and moisture.

TRIPLE LAYER FOAM

Dual-density Comfort Foam with Microfleece is a bonded foam with a soft fleece for added comfort.

DOUBLE LAYER FOAM

Comfort Foam with Microfleece is a single density foam that regulates a goggles inner climate, cushions and provides the perfect skin to goggle interface.

COMFORT FOAM

Comfort Foam is a single density foam that allows for the ideal inner goggle climate.

SILICONE LAYER

The Silicone Layer provides added grip between a goggle strap and on-mountain headwear.

HELMET TECHNOLOGY



HARDSHELL

This helmet technology is matchless in longevity and impact protection. For this reason we use it in our race and rental helmets.



IN MOLD

The shock absorbing inner EPS layer of this technology is injected through the hard outer polycarbonate layer to create a single comprehensive unit that provides perfect protection at a reduced weight.



HELMET CONSTRUCTION

CONSTRUCTION

DUAL DENSITY CORE

This patented core technology is made from EPS with dual densities. This increases the helmets impact performance and suitable according to the FIS RH 2013 standard.

CARBON

The helmets shell is made from carbon fibres, which increases safety and decreases weight. This is why this technology is used for our racing helmets.

LOWER MICROSHELL

The lower edge is coated with polycarbonate in order to avoid scratches and dents in the foam.

VISOR CONSTRUCTION

HEAD Visor Construction is a wind-sealed UV protective shield that allows skiers to ride wearing prescription glasses. Like on a motorcycle helmet the visor can be pulled down to protect the eyes while riding.

TOOLFREE CHINGUARD

The angle of our all-new Toolfree Chinguard can be adjusted individually, without using any tools. The chinguard can also be taken off, when not needed for training, or racing gates.

VENTILATION

ADJUSTABLE VENTILATION

The opening of the ventilation ducts on the top of the helmet may be adjusted continuously by means of a slide control.

THERMAL VENTILATION

Thermal Ventilation is our automatic ventilation system which leads warm air away from the head to the outside without allowing any cold air to the inside.

ACTIVE BOTTOM EDGE

An Active Bottom Edge in HEAD helmets reduces goggle fogging by delivering active airflow. It does this by allowing air to be drawn from the goggles through the helmet.

VENTURI EFFECT

The Venturi Effect creates the ideal inner helmet climate. It does so when air passing over the helmet draws out heat and moisture for the inner shell.

LINING

MICROFUR

Microfur is both warming and comfortable on the skin. As a helmet lining it creates the perfect fit and feel for all-day shredding.

MICROFLEECE

The soft Microfleece material has several functions: it feels good, draws moisture from the skin and transports it away from the head.

BEANIE LINER

The soft lining material of the Beanie Liner adapts perfectly to the head and thus avoids any pressure points and the unpleasant entering of cold air. Molded-in mesh zones let heat and moisture escape to the outside and, together with the ventilation system, ensure a pleasant head climate.

COMFORT ZONE LINER

Soft liner pads provide perfect fit & comfort at a fraction of the weight.

CANTILEVER

A special liner construction that allows the fit system free movement without creating pressure points and wrinkles.

EARPADS & FITTING

NECKGATOR

The Neckgator provides comfort and warmth to the helmet wearer. It adds comfort, fit and excludes the elements.

REMOVABLE EARPADS/NECKGATOR

These ear pads and neckgators can be removed to suit the variable weather conditions and for cleaning.

360° BOA FIT

The 360° Fit system by BOA evenly adjusts the fit of the helmet to all shapes of head.

270° BOA FIT

The 270° Fit system by BOA evenly adjusts the fit of the helmet to all shapes of head.

HEAD 3D FIT

Head 3D Fit allows an exact horizontal as well as vertical adjustment of the helmet to the shape of your head.

HEAD 2D FIT

The size adjustment system may be varied horizontally in order to individually adjust the helmet to your head.

METAL CHINSTRAP BUCKLE

The Metal Chinstrap Buckle is both durable and tactile. Made from metal it also adds to the look of a HEAD helmet.

CERTIFICATION

CE EN 1077:2007 CLASS B

CE EN 1077 is the European standard for ski & snowboard helmets, taking into account the results of collision tests to ascertain dampening and puncture resistant qualities of the outer shell. Class B of this certificate certifies helmets with soft ear protectors.

CE EN 1077:2007 CLASS A

The certification procedure for Class A is used for racing helmets with hard ear protectors, requiring high standards of puncture resistance.

ASTM F 2040

The North American equivalent to the European CE-Test uses comparable methods.

FIS RH 2013

These helmets comply with FIS GS/SG/DH helmet regulations.

HELMET FITTING



FIND THE RIGHT SIZE

Measure your head circumference with a tape measure which you apply above your ears.



PUTTING ON THE HELMET

helmet and adjusting the chin straps The helmet shall sit tightly on your head directly above your eyebrows. Adjust the two chin straps so that they solidly fix and hold the helmet.



CHECK FIT WITH GOGGLES

In order to check the perfect fit of the helmet, please put on your goggles. There should be no gap between the upper edge of your goggles and the helmet.



ACCESSORIES



WINTER COLLECTION 2017-18



HEAD[®]

REBELS TRAVELBAG

ARTICLE NUMBER

383007

FEATURES

Big wheelee bag for ski pros and world travelers
Additional zipper on the top to access main compartment
Inline Skating wheels
Long stowable pull handle for easy carrying;
Additional compartment at the top
Straps for tightening can also be hidden

DIMENSIONS 55 x 46 x 81 cm

VOLUME 88,7 L

WEIGHT 4 kg



REBELS BACKPACK

ARTICLE NUMBER

383017

FEATURES

Daypack with integrated laptop pocket
Variable opening
Bag width adjustable
Fully adjustable padded dorsal strap system
Bottle pocket & jacket holder

DIMENSIONS 35 x 48 x 22 cm

VOLUME 25,8 L

WEIGHT 0,68 kg



REBELS RACING BACKPACK

ARTICLE NUMBER

383037 Large

383047 Small

FEATURES

Big backpack for racers, coaches and tech-reps
One front and two side pockets
Fleece lined goggle pocket
Developed in collaboration with racing department.
Auto-lock zipper

DIMENSIONS 53 x 65 x 35 cm (Large)

33 x 50 x 33 cm (Small)

VOLUME 79,2 L (Large)

36,0 L (Small)

WEIGHT 1,60 kg (Large)

1,26 kg (Small)



REBELS DOUBLE SKIBAG

ARTICLE NUMBER

383027

FEATURES

Protective bag for 2 pairs of skis
Two wheels for carrying comfort
Easy-to-adjust compression straps
Diagonal zipper for easy access
Velcro handle for carrying comfort
Additional pole compartment

DIMENSIONS 203 x 18 x 28 cm

VOLUME 67,2 L

WEIGHT 2,76 kg



SINGLE SKI BAG

ARTICLE NUMBER

383057

FEATURES

Protective skibag for one pair of skis
Extendable to a length of 200 cm
Equipped with two buckles and easy-to-adjust compression straps diagonal zipper
Velcro handle for carrying comfort

DIMENSIONS 200 x 12 x 22 cm

VOLUME 55,2 L

WEIGHT 0,93 kg

DOUBLE SKIBAG

ARTICLE NUMBER

383067

FEATURES

Protective skibag for two pairs of skis
Extendable to a length of 200 cm
Equipped with two buckles and easy-to-adjust compression straps diagonal zipper
Velcro handle for carrying comfort

DIMENSIONS 200 x 12 x 27 cm

VOLUME 67,2 L

WEIGHT 1,03 kg



SKI TRAVELBAG

ARTICLE NUMBER

383187

FEATURES

Big wheellie bag with large main and various small compartments
Stowable pull handle
Business card window and high quality wheels

DIMENSIONS 80 x 33,7 x 33 cm

VOLUME 73,4 L

WEIGHT 2 kg



BOOT BACKPACK

ARTICLE NUMBER

383087

FEATURES

Zippered main ski boot compartment
Additional shoe and accessories compartment

DIMENSIONS 32,4 x 38 x 25,4 cm

VOLUME 36,2 L

WEIGHT 0,47 kg



BOOT BAG

ARTICLE NUMBER

383077

FEATURES

Velcro handle for carrying comfort
NEW opening system: No more dirty feet while getting into your ski boots
Adjustable carrying straps

DIMENSIONS 45,7 x 40 x 25 cm

VOLUME 28,4 L

WEIGHT 0,52 kg



FREERIDE SINGLE SKIBAG

ARTICLE NUMBER

383127

FEATURES

Protective ski bag for one pair of skis
Length 185 cm - extendable to 195 cm
Equipped with two buckled, easy to adjust compression straps and a comfortable carrying strap
Velcro handle for carrying comfort

DIMENSIONS 185 x 25 x 5 cm

VOLUME 59,4 L

WEIGHT 0,73 kg



FREERIDE BOOT BAG

ARTICLE NUMBER

383147

FEATURES

Boot bag for one pair of ski boots
Zippered main compartment
Easy opening system
Adjustable shoulder strap

DIMENSIONS 39 x 41 x 29 cm

VOLUME 25,8 L

WEIGHT 0,49 kg



FREERIDE BACKPACK

ARTICLE NUMBER

383107

FEATURES

Horizontal and vertical ski carry options
Vertical snowboard carry straps
Storable ski carry and ice axe straps
Helmet carrying system
Additional back opening
Including rain shelter
Lightweight material
Easy tightening system

DIMENSIONS 30 x 50 x 21 cm

VOLUME 23,3 L

WEIGHT 1,04 kg



LEARJET

ARTICLE NUMBER

374435

FEATURES

Water resistant nylon material
Durable ripstop construction
Highquality YKK Zipper
Heavy duty webbing reinforcements
Bottom & edge protection
3 stop telescope handle
Comfy neoprene handle

DIMENSIONS 55 x 35 x 28 cm

VOLUME 55 L



TRAVELBAG SM

ARTICLE NUMBER

374425

FEATURES

Water resistant nylon material
Durable ripstop construction
Highquality YKK Zipper
Heavy duty webbing reinforcements
Bottom & edge protection
Velcro adjustable packing compartments
Laundry bag, 2 stop telescope handle
3 Comfy neoprene handle

DIMENSIONS 75 x 40 x 30 cm

VOLUME 95 L



WOMAN SINGLE SKIBAG

ARTICLE NUMBER

383157

FEATURES

Protective skibag for one pair of skis
Comfortable carrying straps
and solid compression straps
HEAD embroidery
Cushioned handle for carrying comfort
Velcro handle

DIMENSIONS 185,4 x 14,6 x 23 cm

VOLUME 48,0 L

WEIGHT 1,01 kg



WOMEN BAG

ARTICLE NUMBER

383177

FEATURES

Bag for one pair of ski boots and accessories
Zippered main compartment
and external pocket
Cushioned handle for carrying comfort
Hidden, adjustable shoulder strap

DIMENSIONS 38 x 62 x 25,4 cm

VOLUME 38,8 L

WEIGHT 0,75 kg





WORLD CUP SG

ARTICLE NUMBER

381026

FEATURES

Original bent World Cup Racing Pole, 7075 Aluminum, Soft Downhill Grip c/w Torx Screw Black, Race Strap, DH/SG Cone Basket Neon Yellow, Carbide Tip Alpine

DIAMETER 18 mm

LENGTH 110-135 cm

COLORS White/Black/Yellow



WORLD CUP SL

ARTICLE NUMBER

381056

FEATURES

SL World Cup Racing Pole, 7075 Aluminum, Soft Downhill Grip c/w Torx Screw Black, Race Strap, Alpine Race Basket 50mm Neon Yellow, Carbide Tip Alpine

DIAMETER 18 mm

LENGTH 110-140 cm

COLORS White/Black/Yellow



WORLD CUP SL PROTECTOR

ARTICLE NUMBER

381346

FEATURES

Universal HEAD branded Hand Protector, Fits on both Junior and Adult SL poles, Includes mounting hard wear, 2 protectors / poly bag



CARBON PRESTIGE

ARTICLE NUMBER

381776

FEATURES

Positive Angle Safety Thermo Grip, Lock Security Strap, Carbide Flex Tip Alpine, Vision Race Basket 50mm

DIAMETER 16 mm Carbon Shaft

LENGTH 105 - 135 cm

COLORS Carbon black/Silver



HEAD AIRFOIL

ARTICLE NUMBER

381956 Black

381916 Neon Blue

381926 Neon Green

381936 Neon Red

381946 Neon Yellow

FEATURES

7075 Aluminum Airfoil, Positive Angle Safety Bi-Injected Soft Grip cw white core, Lock Security Strap, Alpine Race Basket 50 mm, HM Steel Tip

DIAMETER 16 mm

LENGTH 105 - 135 cm

COLORS Black, Neon Blue, Neon Green, Neon Red, Neon Yellow

**MULTI S****ARTICLE NUMBER**

381147 Black/White/Yellow
 381157 Black/Red
 381167 Black/Green

FEATURES

5083 Aluminum,
 Glossy Matte finish,
 Bi-injected Grip,
 Automatic Strap,
 Race Basket 50mm,
 Star Tip

DIAMETER 18 mm
LENGTH 105 - 135 cm
COLORS Black/White/Yellow, Black/Red, Black/Green

MULTI**ARTICLE NUMBER**

381817 White/Grey/Green
 381827 Silver/Grey/Yellow
 381847 Black/Silver/White

FEATURES

5086 Aluminum,
 MOMA Grip,
 Automatic Strap,
 Race Basket 50mm,
 Star Tip

DIAMETER 18 mm
LENGTH 105 - 135 cm
COLORS White/Grey/Green, Silver/Grey/Yellow,
 Black/Silver/White

**HEAD KORE 2 PIECE****ARTICLE NUMBER**

381537

FEATURES

Two-part telescopic pole, 7075 Aluminum,
 AEGON Grip c/w 14cm Foam Extension,
 Lock Security Neoprene strap, LEKI Speed
 Lock 2, Carbide flex tip long, Bandit Basket
 80 mm & Additional 95mm Powder Basket

DIAMETER 16/14 mm
LENGTH 110 - 140 cm adjustable
COLORS Black/Neon Green

**JOY BLACK NEON YELLOW****ARTICLE NUMBER**

381657

FEATURES

High End Woman Pole,
7075 Aluminum, Positive Angle
Safety Thermo Compact Grip,
Lock Security Compact Strap
Neoprene, Ice Steel Tip, Alpine
Race Basket 50 mm

DIAMETER 16 mm

LENGTH 105-125 cm

COLORS Black/Neon/Yellow

JOY WHITE BLACK**ARTICLE NUMBER**

381767

FEATURES

High End Woman Pole,
7075 Aluminum, Positive Angle
Safety Thermo Compact Grip,
Lock Security Compact Strap
Neoprene, Steel Tip, Alpine
Race Basket 50 mm

DIAMETER 16 mm

LENGTH 105-125 cm

COLORS White/Black

JOY**ARTICLE NUMBER**

381677 Teal/White

381687 Black/White

FEATURES

Budget Woman Pole,
5086 Aluminum,
Women-specific SBS Soft Handle,
Automatic Strap,
Race Basket,
Star Tip

DIAMETER 16 mm

LENGTH 105-125cm

COLORS Teal/White, Black/White

**SUPERSHAPE TEAM****ARTICLE NUMBER**

381376

FEATURES

5086 Aluminum,
Kids Plastic Grip,
Buckle strap Kids,
Alpine Race Basket 50 mm,
Steel Tip

DIAMETER 14 mm

LENGTH 70 - 110 cm

COLORS White/Black/Yellow

MONSTER JUNIOR**ARTICLE NUMBER**

381397

FEATURES

Cosmetics sublimated,
5086 Aluminum, Kids Plastic
Grip, Buckle strap Kids, Alpine
Race Basket 50 mm,
Steel Tip

DIAMETER 14 mm

LENGTH 80-105 cm

COLORS Sublimated

JOY GIRL**ARTICLE NUMBER**

381647

FEATURES

5086 Aluminum,
Kids Plastic Grip,
Buckle strap Kids,
Alpine Race Basket 50 mm,
Steel Tip

DIAMETER 14 mm

LENGTH 80 - 105 cm

COLORS White/Pink



RENTAL

WINTER COLLECTION 2017-18



HEAD WAY

ARTICLE NUMBER

- 312375 Balance Track, Length 100
- 312385 Glide Track, Length 125
- 312395 Steer Track, Length 150

DETAILS

- DIMENSIONS 128/85/106
- 119/81/97
- 128/76/111
- BINDINGS SP10 ABS

FEATURES

- ERA 2.0, Early rise
- Composite Radius Construction
- SnakeSkin Surface, Woodcore Torsion Box
- Cap Construction, Black UHM C Base

HEAD®



INSTINCT 83 R

ARTICLE NUMBER
312407 AB

FEATURES

Allride Rocker, ERA 3.0, Structured Surface
Graphene™ Sandwich Cap Construction
Black Structured UHM C Base

DETAILS

LENGTHS 149/156/163/170/177
DIMENSIONS 124/82/109 @ length 170
RADIUS 16,5 @ length 170
BINDINGS 114160 PR 11 MBS Brake 85 [G]
114164 PR 11 Brake 85 [G]



INSTINCT 78

ARTICLE NUMBER
312557 AB

FEATURES

Allride Rocker, Era 3.0, Structured Surface
Graphene™ Wood Core Cap Construction
Black UHM C Base

DETAILS

LENGTHS 142/149/156/163/170/177
DIMENSIONS 131/78/113 @ length 170
RADIUS 13,2 @ length 170
BINDINGS 114160 PR 11 MBS Brake 85 [G]
114164 PR 11 Brake 85 [G]



SHAPE SX R

ARTICLE NUMBER
312417 AB

FEATURES

Allride Rocker, ERA 3.0, Structured Surface
Graphene™ Sandwich Cap Construction
Black UHM C Base

DETAILS

LENGTHS 149/156/163/170/177
DIMENSIONS 125/72/109 @ length 170
RADIUS 12,9 @ length 170
BINDINGS 114160 PR 11 MBS Brake 85 [G]
114164 PR 11 Brake 85 [G]



SHAPE CX R

ARTICLE NUMBER
312617 Track
312707 AB

FEATURES

Allride Rocker, ERA 3.0, Structured Surface
Power Sidewall Jacket, Black UHM C Base

DETAILS

LENGTHS 149/156/163/170/177
DIMENSIONS 127/78/110 @ length 170
RADIUS 13,6 @ length 170
BINDINGS 111567 SP 10 ABS PM
114160 PR 11 MBS Brake 85 [G]
114164 PR 11 Brake 85 [G]



SHAPE RX R

ARTICLE NUMBER
312517 Flat
312527 Track
312537 AB
312547 SLR 2

FEATURES

ERA 2.0, Early rise, Composite Radius
Construction, SnakeSkin Surface
Synthetic core construction
Black UHM C Base

DETAILS

LENGTHS 142/149/156/163/170/177
DIMENSIONS 123/70/106 @ length 170
RADIUS 12,8 @ length 170
BINDINGS 111872 SP 10 ABS Brake 85 [D]
111567 SP 10 ABS PM
114164 PR 11 Brake 85 [G]
114061 SLR 9.0 AC Brake 78 [H]
114160 PR 11 MBS Brake 85 [G]



THE LINK PRO R

ARTICLE NUMBER

312567 Track
312587 black
312597 yellow

FEATURES

ERA 2.0, Early rise, Composite Radius Construction, SnakeSkin Surface, Woodcore, Torsion Box, Cap Construction, Black UHM C Base

DETAILS

LENGTHS 130 (XS)/140 (S)/150 (M)/160 (L)/170 (XL)
DIMENSIONS 125/69/106 @ length 150
RADIUS 10,0 @ length 150
BINDINGS 111567 SP 10 ABS PM
111877 BYS 10 Brake 85 [D]

COLOR CODE



THE LINK R

ARTICLE NUMBER

312437 Track
312447 black
312457 yellow

FEATURES

ERA 2.0, Early rise, Composite Radius Construction, SnakeSkin Surface, Synthetic core construction, Black UHM C Base

DETAILS

LENGTHS 140(S)/150(M)/160(L)/170(XL)/177(XXL)
DIMENSIONS 123/70/106 @ length 170
RADIUS 12,8 @ length 170
BINDINGS 111567 SP 10 ABS PM
111877 BYS 10 Brake 85 [D]

COLOR CODE



RESIDUE R TRACK

ARTICLE NUMBER

314107 Track

FEATURES

Heavy duty twin tip model, mesh top sheet, heavy duty woodcore, UHM C base, Pre-mounted rental track

DETAILS

LENGTHS 109/118/127/136/145/154/163/172/181
DIMENSIONS 112/79/106 @ length 172
RADIUS 19,1 @ length 172
BINDINGS 111567 SP 10 ABS PM



ABSOLUT JOY R SLR 2

ARTICLE NUMBER

312487

FEATURES

LIBRA Graphene-Super Light Weight Distribution, Women's Camber, ERA 3.0, Power Sidewall Jacket, Superlite Composite Core, Structured Surface, Allride Rocker, Tip Protector, Black UHM C Base

DETAILS

LENGTHS 143/148/153/158/163/168
DIMENSIONS 129/79/109 @ length 163
RADIUS 13,5 @ length 163
PLATE SLR II Base
BINDINGS 114168 SLR 9.0 AC Brake 85 [H]



LIGHT JOY R SLR 2

ARTICLE NUMBER

312467

FEATURES

LIBRA Graphene-Super Light Weight Distribution, Women's Camber, ERA 3.0, Power Sidewall Jacket, Structured Surface, Allride Rocker, Tip Protector, Black UHM C Base

DETAILS

LENGTHS 143/148/153/158/163
DIMENSIONS 127/73/107 @ length 158
RADIUS 10,9 @ length 158
PLATE SLR II Base
BINDINGS 114168 SLR 9.0 AC Brake 85 [H]



SUPERSHAPE TEAM R

ARTICLE NUMBER

312607 Track 4.5, Length 87/97/ 107/117
312627 Track 7.5, Length 117/127/ 137
312637 R SLR 2, 312647 R
Length 67/77/87/97/107/117/127/
137/147/157

FEATURES

Jr. Power Frame, ERA 2.0,
Structured Surface, Black UHM C Base

DETAILS

DIMENSIONS

103/65/89 @ length 87 (Track 4.5)
111/67/96 @ length 127 (Track 7.5)
103/65/89 @ length 87 (SLR II)

RADIUS 4,0 @ length 87 (Track 4.5)
8,0 @ length 127 (Track 7.5)
4,0 @ length 87 (SLR II)

BINDINGS 111577 B²YS 4.5 AC Brake 74 [K]
111670 SP 7.5 AC PM
111572 SP 4.5 AC PM
114071 SLR 7.5 AC Brake78 [H]
114073 SLR 4.5 AC Brake 74 [I]



RAZZLEDAZZLE

ARTICLE NUMBER

312997

FEATURES

SnakeSkin Top Sheet, Full FiberJacket,
E base black, Pre-mounted SP 10 Binding

DETAILS

LENGTHS 94
DIMENSIONS 129/90/118 @ length 94
RADIUS 4,2 @ length 94
BINDINGS 111873 SP 10 ABS Brake 110 [D]



SP 13 ABS

ARTICLE NUMBER

114097 SP 13 ABS Brake 85 [D]
Solid Black/White

FEATURES

RX Toe with TRP System, Full Diagonal,
ABS – Anti Blocking System,
Sympro, Rent Heel
STAND HEIGHT 31,0mm
DIN 4 - 13
WEIGHT 2600g
WEIGHT RANGE
From 42kg / from 92 lbs
COLORS Solid Black/White
LENGTH ADJUSTMENT RANGE
Toe 64mm, Heel 60mm
Boot Sole Length: 263–391mm



SP 10 ABS

ARTICLE NUMBER

111872 SP 10 ABS Brake 85 [D]
111566 SP 10 ABS * w/o Brake [D]
111567 SP 10 ABS ** PM
111873 SP 10 ABS * Brake 110 [D]
(6mm screws)
All Solid Black/Anthracite

FEATURES

SX Toe with TRP System, Full Diagonal,
ABS – Anti Blocking System,
Sympro, Rent Heel
STAND HEIGHT 31,0mm
DIN 2.5 - 10
WEIGHT 2560g (*2260g, **1580g)
WEIGHT RANGE
From 26kg / from 57 lbs
COLORS Solid Black/Anthracite
LENGTH ADJUSTMENT RANGE
Toe 64mm, Heel 60mm
Boot Sole Length: 263–391mm



SP 7.5 AC

ARTICLE NUMBER

111670 SP 7.5 AC PM *
Solid Black/Anthracite
111874 SP 7.5 AC Brake 85 [D]
Solid Black/Anthracite

FEATURES

SX Junior Toe with TRP System,
Full Diagonal, AFS Junior,
Sympro, Rent Heel
STAND HEIGHT 31,0mm
DIN 1.5–7.5
WEIGHT 2420g (*1440g)
WEIGHT RANGE
18 - 84kg / 39 - 187 lbs
COLORS Solid Black/Anthracite
LENGTH ADJUSTMENT RANGE
Toe 64mm, Heel 60mm
Boot Sole Length: 263–391mm



SP 4.5 AC

ARTICLE NUMBER

111571 SP 4.5 AC Brake 74 [K]
Solid Black
111572 SP 4.5 AC PM
Solid Black

FEATURES

SX Kid Toe with TRP System, Full Diagonal,
AFS Junior, SX Kid Heel
STAND HEIGHT 25,0mm
DIN 0.75 - 4.5
WEIGHT 1630g
WEIGHT RANGE
10 - 48kg / 22 - 105 lbs
COLOR Solid Black
LENGTH ADJUSTMENT RANGE:
Toe 48mm, Heel 52mm
Boot Sole Length: 191–294mm
AC – Fits Alpine Adult and Children Ski Boots



SR 10

ARTICLE NUMBER

111876 SR 10 Brake 85 [D]
Solid Black/Anthracite

FEATURES

SX Toe with TRP System,
Full Diagonal, Symrent, Rent Heel
STAND HEIGHT 22,0mm
DIN 2.5 - 10
WEIGHT 2140g
WEIGHT RANGE
From 26kg / from 57 lbs
COLORS Solid Black/Anthracite
LENGTH ADJUSTMENT RANGE
Heel: 84mm
Boot Sole Length: 263–351mm



SR 4.5 AC

ARTICLE NUMBER

111574 SR 4.5 AC Brake 74 [K]
Solid Black

FEATURES

SX Kid Toe with TRP System, Full Diagonal,
AFS Junior, Symrent, SX Kid Heel
STAND HEIGHT 15,0mm
DIN 0.75 - 4.5
WEIGHT 1280g
WEIGHT RANGE
10 - 48kg / 22 - 105 lbs
COLOR Solid Black
LENGTH ADJUSTMENT RANGE
Heel: 52mm
Boot Sole Length: 199–255 (*231–287mm)
AC – Fits Alpine Adult and Children Ski Boots



BYS 10

ARTICLE NUMBER

111877 BYS 10 Brake 85 [D]
Solid Black/Anthracite

FEATURES

SX Toe with TRP System,
Full Diagonal, ABS - Anti Blocking
System, Rent Heel
STAND HEIGHT 21,0 mm
DIN 2.5 - 10
WEIGHT 1890g
WEIGHT RANGE From 26 kg / from 57 lbs
COLORS Solid Black/Anthracite

TYROLIA AAATTACK² 13 AT DEMO

ARTICLE NUMBER

114150 TYROLIA AAATTACK²
13 AT DEMO
w/o Brake [F] Solid Black

114151 TYROLIA AAATTACK²
13 AT DEMO

Brake 95 [F] Solid Black

114152 TYROLIA AAATTACK²
13 AT DEMO

Brake 110 [F] Solid Black

FEATURES

FR Pro² AT Toe with TRP System,
AFS Metal, AAATTACK DEMO,
NX FR Heel

DETAILS

STAND HEIGHT 32,0 mm
DIN 4-13
WEIGHT 2250g
(with brake: 2550g)
Boot Sole Length: 259-382mm
WEIGHT RANGE
From 42 kg / from 92 lbs
COLOR Solid Black



TYROLIA AAATTACK² 11 AT DEMO

ARTICLE NUMBER

114154 TYROLIA AAATTACK²
11 AT DEMO
w/o Brake [G] Solid Black

114155 TYROLIA AAATTACK²
11 AT DEMO

Brake 90 [G] Solid Black/White

114156 TYROLIA AAATTACK²
11 AT DEMO

Brake 100 [G] Solid Black

FEATURES

FR Pro² AT Toe with TRP System,
AFS Metal, AAATTACK DEMO,
SX FR Heel, Solid Colored

DETAILS

STAND HEIGHT 29,5 mm
DIN 3-11
WEIGHT 2130g
(with brake: 2430g)
Boot Sole Length: 259-382mm
WEIGHT RANGE
From 31 kg / from 67 lbs
COLOR Solid Black



ADULT RENTAL

ARTICLE NUMBER

381425

DIAMETER 18 x 1 mm

LENGTH 110 - 135 cm

COLORS Color Coded Basket

FEATURES

7075 Aluminum,
Cosmetics Screen Printed,
Length Indication in both cm and
Inch, Large Surface Color Coding,
Soft Touch Grip

ADULT RENTAL SUBLIMATED

ARTICLE NUMBER

381447

DIAMETER 18 x 1 mm

LENGTH 110 - 135 cm

COLORS Color Coded Basket

FEATURES

7075 Aluminum,
Cosmetics Sublimated and
Customizable, Length Indication
in both cm and Inch,
Large Surface Color Coding,
Soft Touch Grip



JUNIOR RENTAL

ARTICLE NUMBER

381435

DIAMETER 16 x 0,8 mm

LENGTH 70 - 105 cm

COLORS Color Coded Basket

FEATURES

7075 Aluminum,
Cosmetics Screen Printed,
Length Indication in both cm and
Inch, Large Surface Color Coding,
Soft Touch Grip

JUNIOR RENTAL SUBLIMATED

ARTICLE NUMBER

381457

DIAMETER 16 x 0,8 mm

LENGTH 70 - 105 cm

COLORS Color Coded Basket

FEATURES

7075 Aluminum,
Cosmetics Sublimated and
Customizable, Length Indication
in both cm and Inch,
Large Surface Color Coding,
Soft Touch Grip

RENTAL MAIN FEATURES

- + **BAR CODE STICKERS** AVAILABLE ON ALL MODELS
- + **BAR CODE HOLDER** ON ALL MODELS FEATURING VELCRO STRAP
- + **27.5 M NEW TAMPO PRINTED SINGLE CODE** WITH MM INDICATION AVAILABLE ON ALL MODELS
- + **HIGH RESISTANCE PU HEEL AND TOE PU SHELL ON ALL MODELS** (INCLUDING "Z1, Z2, Z3" JUNIOR BOOTS)
- + **SANITIZED® CHARCOAL FOOTBED**
- + **REINFORCED BUCKLES** FOR ADDED DURABILITY
- + **EZON 2 BYS: 1 SOLE LENGTH, 2 SHELLS, 2 SIZES PER SHELL**
BOOT SOLE: 365MM
- + **NEXT EDGE BYS: 2 SOLE LENGTHS, 4 SHELLS, 2 SIZES PER SHELL**
BOOT SOLES: 289MM AND 329MM
- + **BYS: 3 SOLE LENGTHS, 6 SHELLS, 2 SIZES PER SHELL**
BOOT SOLES: 289MM, 329MM, AND 365MM



VECTOR EVO 100 HT

ARTICLE NUMBER

606600

FEATURES

Bi-Inj dynamic frame, Easy entry shell design, Stiffer/softer flex adjust., Single canting
Rear support tuning, Evo Balance

LINER

EVO Perfect Fit S liner
Sanitized® charcoal footbed
HP frame footbed
40 mm velcro strap

BUCKLES

4 micro-adjustable alloy buckles
1 Supermacro ratchet

DETAILS

LEVEL Expert
FLEX INDEX 100/90
SIZES 250-265-...-305-310-320

SHELL

PU

LAST

Last	98	100	102
Size	25.5	26.5	27.5

COLOR Trsp. Anth./
Black-Green



VECTOR EVO 90 HT W

ARTICLE NUMBER

606601

FEATURES

Bi-Inj dynamic frame, Easy entry shell design, Stiffer/softer flex adjust., Single canting
Rear support tuning, Evo Balance

LINER

Women's Evo Perfect Fit S liner
Sanitized® charcoal footbed
HP frame footbed
40 mm velcro strap

BUCKLES

4 micro-adjustable alloy buckles
1 Supermacro ratchet

DETAILS

LEVEL Expert
FLEX INDEX 90/80
SIZES 230-235-...-275

SHELL

PU

LAST

Last	96	98	100
Size	24.5	25.5	26.5

COLOR Trsp. Gray-Yellow



ADVANT EDGE 95 HT

ARTICLE NUMBER

606603

FEATURES

Bi-Inj. control frame, Hi-Top Tech Duo Flex, Easy entry shell design
Stiffer/softer flex adjust., Single canting, Adjustable rear spoiler
All Ride Balance

LINER

Comfort liner
Sanitized® charcoal footbed
40mm velcro strap

BUCKLES

4 micro-adjustable alloy buckles
2 Double Power levers
1 Supermacro ratchet

DETAILS

LEVEL Advanced

FLEX INDEX 95/85

SIZES 250-255-

260-265-...-305

SHELL PU

LAST C 2100cc

Last	100	102	104
Size	25.5	26.5	27.5

COLOR Trsp. Red/ Black



ADVANT EDGE 85 HT

ARTICLE NUMBER

607311

FEATURES

Bi-Inj. control frame, Hi-Top tech, Duo flex, Easy entry shell design,
Stiffer/softer flex adjust., Single canting, Adjustable rear spoiler,
All ride Balance

LINER

Comfort liner
Sanitized® charcoal footbed
40 mm velcro strap

BUCKLES

4 micro-adjustable alloy buckles
1 Supermacro ratchet

DETAILS

LEVEL Intermediate

FLEX INDEX 85

SIZES 250-255-...-305-310-

320-330-340

SHELL PU/SL

LAST C 2100cc

Last	100	102	104
Size	25.5	26.5	27.5

COLOR Yellow/Black



ADVANT EDGE 85 HT W

ARTICLE NUMBER

607305

FEATURES

Bi-Inj. control frame, Hi-Top Tech, Duo Flex, Easy entry shell design
Single canting, Double adjustable cuff, All Ride Balance

LINER

Women's comfort liner
Women auto adaptive tech.
Sanitized® charcoal footbed
40mm velcro strap

BUCKLES

4 micro-adjustable alloy buckles
2 Double Power levers
1 Supermacro ratchet

DETAILS

LEVEL Advanced

FLEX INDEX 85/75

SIZES 220-225-

230-235-...-275

SHELL PU

LAST C 2100cc

Last	98	100	102
Size	24.5	25.5	26.5

COLOR Anthracite/Black



ADVANT EDGE 75 HT W

ARTICLE NUMBER
607316

FEATURES

Bi-Inj. control frame, Hi-Top Tech, Duo Flex, Easy entry shell design, Single canting, Double adjustable cuff, All Ride Balance

LINER

Women's comfort liner
Women auto adaptive tech.
Sanitized® charcoal footbed
40mm velcro strap

BUCKLES

4 micro-adjustable alloy buckles
1 Supermacro ratchet

DETAILS

LEVEL Intermediate

FLEX INDEX 75

SIZES 220-225-
230-235-...-275

SHELL PU/SL

LAST C 2100cc

Last	98	100	102
Size	24.5	25.5	26.5

COLOR Gray- yellow



NEXT EDGE 75 HT W

ARTICLE NUMBER
607318

FEATURES

Tri-Inj. energy frame, Easy entry shell design, Double adjustable profile, Double canting
All Ride Balance

LINER

Women's comfort liner
Fleece lining
Sanitized® charcoal footbed
30 mm velcro strap

BUCKLES

4 micro-adjustable alloy buckles
1 Supermacro ratchet

DETAILS

LEVEL Intermediate

FLEX INDEX 75

SIZES 220-225-
230-235-...-275

SHELL PU/SL

LAST C 2100cc

Last	98	100	102
Size	24.5	25.5	26.5

COLOR Anthracite/Black



NEXT EDGE 85 HT

ARTICLE NUMBER
607312

FEATURES

Tri-Inj. energy frame, Easy entry shell design, Double adjustable profile, Stiffer/softer flex adjust
Double canting
All Ride Balance

LINER

Comfort liner
Fleece lining, Sanitized® charcoal footbed, 40 mm velcro strap

BUCKLES

4 micro-adjustable alloy buckles
1 Supermacro ratchet

DETAILS

LEVEL Intermediate

FLEX INDEX 85

SIZES 250-255-
260-265-...-305

SHELL PU/SL

LAST C 2100cc

Last	100	102	104
Size	25.5	26.5	27.5

COLOR Anthracite/Black-yellow



NEXT EDGE 65 HT W

ARTICLE NUMBER
606622

FEATURES

Tri-Inj. energy frame, Easy entry shell design, Double canting

LINER

Women's comfort liner
Fleece lining, Sanitized® charcoal footbed, 30 mm velcro strap

BUCKLES

4 plastic buckles
1 Supermacro ratchet

DETAILS

LEVEL Intermediate

FLEX INDEX 65

SIZES 230-235-...-275

SHELL PU/SL

LAST C 2100cc

Last	98	100	102
Size	24.5	25.5	26.5

COLOR Black



NEXT EDGE 75 HT

ARTICLE NUMBER
606621

FEATURES

Tri-Inj. energy frame, Easy entry shell design, Double canting

LINER

Comfort liner
Sanitized® charcoal footbed
40 mm velcro strap

BUCKLES

4 plastic buckles
1 Supermacro ratchet

DETAILS

LEVEL Intermediate

FLEX INDEX 75

SIZES 250-255-
260-265-...-305

SHELL PU/SL

LAST C 2100cc

Last	100	102	104
Size	25.5	26.5	27.5

COLOR Anthracite



FX 65 HT

ARTICLE NUMBER
606625

FEATURES

Power control frame

LINER

Comfort liner
Sanitized® charcoal footbed

BUCKLES

2 plastic buckles,
1 micro-adjustable wide-body alloy buckles, 1 Supermacro ratchet

DETAILS

LEVEL Intermediate

FLEX INDEX 65

SIZES 260-265-...-305

SHELL PU/SL

LAST EC 2200cc

Last	102	104	106
Size	25.5	26.5	27.5

COLOR Black



FX 55 HT W

ARTICLE NUMBER

606626

FEATURES

Power control frame

LINER

Women Comfort liner
Sanitized® charcoal footbed

BUCKLES

2 plastic buckles,
1 micro-adjustable wide-body
alloy buckles, 1 Supermacro ratchet

DETAILS

LEVEL Intermediate

FLEX INDEX 55

SIZES 230-235-...-275

SHELL PU/SL

LAST EC 2200cc

Last	100	102	104
Size	26.5	26.5	27.5

COLOR White



NEXT EDGE B.Y.S. 80 HT

ARTICLE NUMBER

605719

FEATURES

Tri-Inj. energy frame, Easy entry
shell design, Double canting
2 sole length

LINER

Comfort liner, Sanitized® charcoal
footbed, 40 mm velcro strap

BUCKLES

4 micro-adjustable plastic
buckles
1 Supermacro ratchet

DETAILS

LEVEL Intermediate

FLEX INDEX 80

SIZES 235-245

(Black Woman constr.)

250-255-...-265

(Black Man Constr.)

270-275-...-305

(Yellow Man Constr.)

SHELL PU/SL

LAST C 2100cc

Last	100	102	104
Size	25.5	26.5	27.5

COLOR Black/White



CUBE 3 80 HT

ARTICLE NUMBER

606627

FEATURES

Power control frame
Integrated AutoSkiWalk

LINER

Comfort quick entry liner
Sanitized® charcoal footbed
35 mm velcro strap

BUCKLES

2 micro-adjustable plastic
buckles, 1 micro-adjustable
wide-body alloy buckles,
1 Supermacro ratchet

DETAILS

LEVEL Intermediate

FLEX INDEX 80

SIZES 260-265-...-305

SHELL PU/SL

LAST EC 2200cc

Last	102	104	106
Size	25.5	26.5	27.5

COLOR Black / Anth.



EZON 2 BYS HP

ARTICLE NUMBER

605740 (women)

FEATURES

1 sole lengths, DIN interface for all
rental bindings

LINER

Comfort liner, Sanitized® charcoal
footbed, Prepared for heating
System, 35 mm velcro strap

BUCKLES

4 plastic buckles
1 Supermacro ratchet

DETAILS

LEVEL Intermediate

SIZES 310-320-330-340

Man Constr.

SHELL PU/SL

COLOR Black / White



CUBE 3 70 HT W

ARTICLE NUMBER

606628

FEATURES

Power control frame
Integrated AutoSkiWalk

LINER

Comfort quick entry liner
Sanitized® charcoal footbed
35 mm velcro strap

BUCKLES

2 micro-adjustable plastic
buckles, 1 micro-adjustable
wide-body alloy buckles,
1 Supermacro ratchet

DETAILS

LEVEL Intermediate

FLEX INDEX 70

SIZES 230-235-...-265

SHELL PU/SL

LAST EC 2200cc

Last	100	102	104
Size	25.5	26.5	27.5

COLOR Gray



B.Y.S.

ARTICLE NUMBER

605745

FEATURES

3 sole Lengths, DIN interface for
all rental bindings

LINER

Comfort liner, Sanitized® charcoal
footbed, Prepared for heating
System

BUCKLES

3 plastic buckles
1 Supermacro ratchet

DETAILS

LEVEL Beginner

FLEX INDEX 70

SIZES

235-245-...-265 (Black)

275-285-...-305 (Yellow)

315-310-...-340 (Silver)

SHELL PU/SL

COLOR Anthracite



RAPTOR 50 HT

ARTICLE NUMBER	BUCKLES
607335	4 plastic buckles
FEATURES	DETAILS
Jr racing flex tuning	LEVEL Advanced
Adult norm (size 220 up)	FLEX INDEX 50
	SIZES 200-210-220-...-265
LINER	SHELL PU/SL
Junior Team liner	COLOR Yellow/White
Self-shaping footbed	



Z3 HT

ARTICLE NUMBER	BUCKLES
607340	3 plastic buckles
FEATURES	DETAILS
Jr high top tech, Duo flex, Vario Last, Easy entry shell construction, Junior norm, Design your boot stickers	LEVEL Intermediate
	SIZES 235-245
	255-265
	SHELL PU/SL
	COLOR Anthracite/White
LINER	
Junior rental liner	
Comfort footbed	



RAPTOR 40 HT

ARTICLE NUMBER	BUCKLES
607337	3 plastic buckles
FEATURES	DETAILS
Jr racing flex tuning	LEVEL Advanced
Adult norm	SIZES 185-190-...-245
	SHELL PU/SL
LINER	COLOR Yellow/White
Junior Team liner	
Self-shaping footbed	



Z2 HT

ARTICLE NUMBER	BUCKLES
607342	2 plastic buckles
FEATURES	DETAILS
Jr high top tech, Duo flex, Vario Last, Easy entry shell construction, Junior norm, Design your boot stickers	LEVEL Beginner
	SIZES 195-205
	215-225
	SHELL PU/SL
	COLOR Anthracite/White
LINER	
Junior rental liner	
Comfort footbed	



Z1 HT

ARTICLE NUMBER	BUCKLES
607344	1 plastic buckle
FEATURES	DETAILS
Jr high top tech, Duo flex, Vario Last, Easy entry shell construction, Junior norm, Design your boot stickers	LEVEL Beginner
	SIZES 155-165
	175-185
	SHELL PU/SL
	COLOR Anthracite/White
LINER	
Junior rental liner	
Comfort footbed	

PROTECTION



HEAD®

RENTAL COLLECTION



RENTAL SIZE ADJUSTER

Rental Size Adjuster is super durable and provides quick and easy adjustability.

SD+D COMPATIBLE

SD+D Compatibility means that a product is compatible with HEAD rental helmet storage systems. It allows for safe storage, easy drying and leads to a longer life of products.

COLOR CODED

Rental Colour Coding allows shop staff to quickly and easily determine a product's size and compatibility.

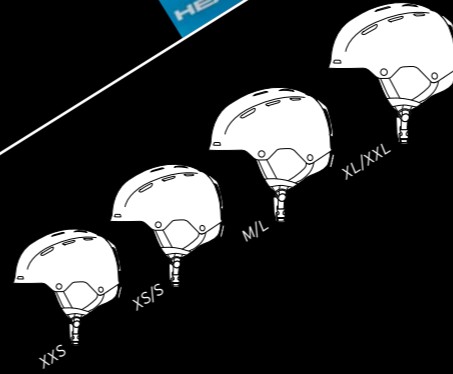

4 COLORS + 4 SIZES

The all-new T-Series comes in four sizes, all featuring their own specific shell mold. This is especially important on smaller sizes, where weight and fit is crucial to assure the protective qualities of a helmet.

T-SERIES
DEVELOPED AND BUILT FOR RENTAL



HELMET STORAGE RACK

HEAD has the solution for efficient storage of helmets: the HELMET STORAGE RACK can be adjusted to the space and quantity requirements of the client and provides both space and easy access for up to 324 helmets on a floor space of 3 m².

HELMET STORAGE RACK 150	HELMET STORAGE RACK 200	HELMET STORAGE RACK 240
375502	375512	375522
for 180 helmets	for 252 helmets	for 324 helmets

HELMET DRYING RACK

In addition to the advantages of the HELMET STORAGE RACK, the HELMET DRYING RACK guarantees rapid and effective drying of the helmets via an integrated drying module. Warm air is directed inside the helmet via the AIRDOCKs and dries the helmets from the inside out, thus reducing drying time to a minimum. The optional ionization tube integrated directly into the air intake also prevents development of odor in the helmets. Both the HELMET STORAGE RACK and the HELMET DRYING RACK are available in widths of 150 cm, 200 cm and 240 cm as free-standing racks on legs. Existing track Systems of the brand MONTANA can be integrated if required.

HELMET DRYING RACK 150	HELMET DRYING RACK 200	HELMET DRYING RACK 240
375532	375542	375552
for 180 helmets	for 252 helmets	for 324 helmets

HELMET WALLDRYER 100

375572

The helmet WALLDRYER 100 completes the portfolio of the SD + D System; it can hold 60 helmets on only one meter or three feet of wall space. Helmets attached to the System can be automatically dried during storage. Standard household power supply can be used to operate the unit on 220 V or 110 V. This not only makes the smallest version of a full-feature SD + D System an easy step into the System, but it also fulfills the needs of smaller operations. The SD + D HELMET WALLDRYER 100 racks can be used free standing or standing against a wall.



FLIP CLIP RAIL

375442 1 meter
375452 2 meter
Tracks for the simple and individual assembly of the RENTAL INTERFACE. In the 1- or 2-meter version, the FLIP CLIP RAIL offers space for 3 or 6 rental interfaces.



HEAD SANITIZER

375462
With this easy-to-operate stainless-steel appliance you can disinfect rental shoes and helmets quickly and efficiently. Three spray jets ensure even distribution of the disinfectant over the whole shoe or helmet for controlled sterilization thereby preventing development of odors. The included table ensures an ideal working height and practical storage space.



RENTAL INTERFACE

375412
The starting point for the modular HEAD SD + D System. An interface offers space for space-saving and efficient storage of 3 helmets and can be used together with the FLIP CLIP RAIL, HELMET STORAGE & DRYING RACK, and HELMET WALLDRYER.



TRACER

ARTICLE NUMBER

329107 black (SR)
329117 apple (SR)
329207 white (JR)
329217 blue (JR)

FEATURES

SD+D Compatible, Hardshell Technology
Thermal Ventilation, Rental Goggle Retainer
Speedlock Buckle, Rental Colour Coding
Rental Size Adjustment

SIZES SR

XS/S	M/L	XL/XXL
52-55 cm	56-58 cm	59-63 cm

SIZES JR

XXS	XS/S	M/L
48-51 cm	52-55 cm	56-58 cm

TEN

ARTICLE NUMBER

329607 black (SR)
329617 apple (SR)
329907 white (JR)
329917 blue (JR)

FEATURES

Hardshell Technology, Thermal Ventilation,
Rental Goggle Retainer, Speedlock Buckle,
Rental Colour Coding, Rental Size Adjustment

SIZES SR

XS/S	M/L	XL/XXL
52-55 cm	56-58 cm	59-63 cm

SIZES JR

XXS	XS/S	M/L
48-51 cm	52-55 cm	56-58 cm



SR



JR

RENTAL SR

ARTICLE NUMBER

329513 black (SR)

329813 white (JR)

FEATURES

Hardshell Technology, Thermal Ventilation,
Rental Goggle Retainer, Speedlock Buckle,
Rental Colour Coding, Rental Size Adjustment

SIZES SR

XS/S	M/L	XL/XXL
52-55 cm	56-58 cm	59-63 cm

SIZES JR

XXS	XS/S	M/L
48-51 cm	52-55 cm	56-58 cm

FLEXOR UNIT R / JR UNIT R

ARTICLE NUMBER

395453 Senior

395463 Junior

FEATURES

SAS TEC viscoelastic foam
REMOVABLE protection unit
3D mesh
NYLON fabric POLYGIENE

SIZES

XXS - XL / XXL



SENIOR / BACK



JUNIOR / BACK



SENIOR / BACK



JUNIOR / BACK



SCAN-BARCODE



JUNIOR / FRONT



SENIOR / FRONT



Removable Protection Unit

SNOWBOARD

RENTAL COLLECTION

HEAD®



LIQUID FRAMEWALL

WE JUST MADE OUR AWARD-WINNING FRAMEWALL EVEN BETTER

Liquid Framewall increases the durability of our boards and makes for a smoother ride at the same time. A unique moulded PU Framewall creates a seamless shock barrier for super resilience. The three-dimensional build of the Liquid Framewall covers the boards top sheet and prevents it from chip-

ping or other external hazards. It's soft material is even able to recover after an impact:

The three-dimensional build of the sidewall covers the boards top sheet and prevents it from chipping and other external hazards, which is resulting in delamination.

The FRAMEWALL is the first 360° protector on a snowboard - that stretches the boards durability considerably!

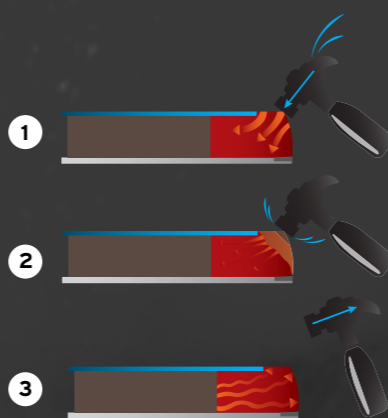

WOMAN SNOWBOARD RENTAL SYSTEM: LIBRA

HEAD BUILDS WOMEN'S EQUIPMENT FROM SCRATCH, FOCUSING ON FEATURES PARAMOUNT TO GIRLS; THESE ARE WEIGHT, BALANCE AND CONTROL ALL OF WHICH AID PROGRESS AND DELIVER A MORE SUPPORTIVE RIDE.

OUR WOMEN'S SNOWBOARD RENTAL PROGRAM IS NEXT LEVEL RIDING FOR GIRLS.

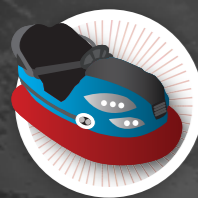

LIBRA LFW 4D
The most versatile and durable rental board out there, featuring the all new Liquid Framewall - developed to ride, for women who rent.

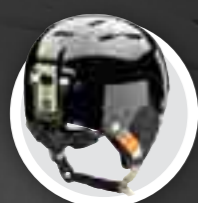

AIR YOUTH
Full action requires full protection.



650 4D BOA FOCUS WMN
High performing rental boot for everyday use. Built for women who know their roastbeefs from their melons.

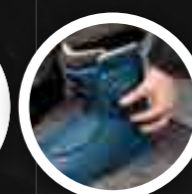

P THREE 4D
Simple bulletproof rental binding in retail look.

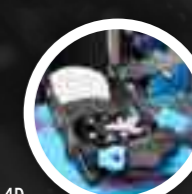

THE 4D SNOWBOARD RENTAL SYSTEM

HEAD BRINGS YOU 4D - PERFECT SETUP, MOST EFFICIENT



We face each of our customers individually, cater to for their perfect setup when renting equipment. Having a positive experience when riding is the key driver to returning customers, no matter what age, gender, ability level or family situation they are - everyone has very own specific needs, which the HEAD 4D System and its wide product portfolio addresses.

And all of that in even less time. If you had to explain the all new 4D System with one word, it would be: Efficiency. But 4D also stands for functionality, reliability and innovation: It is the first snowboard rental System with integrated color coding for boots, boards AND bindings.

The all new 4D System manages it to cater for the perfect setup for every single customer of yours, and at the same time, being the easiest, quickest & most efficient snowboard rental System on the market. Although the benefits of 4D can only be fully exploited by using 4D compatible products, each product can also be used by itself or combined with non-4D products - thanks to its modular structure.



4D EFFICIENCY

With its fully integrated color coding, HEAD 4D snowboard rental Systems manages it to guarantee a perfect setup based on your customers boot size. **This makes the rental process quick and easy.**

Mondo Point

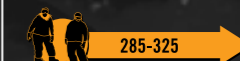



FLOCKA LFW 4D

ARTICLE NUMBER

337006 FLOCKA LFW 4D + SpeedDisc
337066 FLOCKA LFW 4D

Sizes	Contact	Med. stance (cm)
146	109,0	51
151	111,0	53
149	110,5	52
154	114,5	56
159	114,9	58
158	114,9	58
163	119,9	60
168	124,9	60



FLOCKA LFW 4D JR

ARTICLE NUMBER

337106 FLOCKA FW 4D JR + SpeedDisc
337166 FLOCKA FW 4D JR

Sizes	Contact	Med. stance (cm)
90	60	30
100	67	32
110	75,3	36
120	82,6	42
130	92,0	44
140	101,0	46

FEATURES FLOCKA FW 4D

- 4D compatible
- Flocka shape
- Liquid FRAMEWALL
- UVR topsheet
- Poplar wood core
- Easy maintenance base
- Retail inspired design



LIBRA LFW 4D

ARTICLE NUMBER

337206 LIBRA LFW 4D + SpeedDisc
337266 LIBRA LFW 4D

Sizes	Contact	Med. stance (cm)
138	-	50
142	-	52
146	109	56
151	111	58
149	110,5	60
154	114,5	60



FEATURES

- 4D compatible
- LIBRA – Women snowboard rental system
- Flocka shape
- Liquid FRAMEWALL
- UVR topsheet
- Poplar wood core
- Easy maintenance base
- Women inspired design



ROCKA FW 4D

ARTICLE NUMBER

337304 ROCKA FW 4D + SpeedDisc
337354 ROCKA FW 4D

Sizes	Contact	Med. stance (cm)
146	58	50
151	60	52
149	60	52
154	64	56
159	66	58
158	66	58
163	68	60
168	68	60



ROCKA FW 4D JR

ARTICLE NUMBER

337404 ROCKA FW 4D JR + SpeedDisc
337454 ROCKA FW 4D JR

Sizes	Contact	Med. stance (cm)
120	50	42
130	52	44
140	54	46

ROCKA FW 4D KID

ARTICLE NUMBER

337504 ROCKA FW 4D KID + SpeedDisc
337554 ROCKA FW 4D KID

Sizes	Contact	Med. stance (cm)
90	38	30
100	40	32
110	44	36

NO FRAMEWALL ON ROCKA FW 4D KID.

FEATURES ROCKA FW 4D

- 4D compatible
- Rocka shape
- Framework
- UVR topsheet
- Poplar wood core
- Easy maintenance die-cut base



ROCKA 4D

ARTICLE NUMBER

337606 ROCKA 4D + SpeedDisc
337666 ROCKA 4D

Sizes	Contact	Med. stance (cm)
146	58	50
151	60	52
149	60	52
154	64	56
159	66	58
158	66	58
163	68	60
168	68	60



ROCKA 4D JR

ARTICLE NUMBER

337706 ROCKA 4D JR + SpeedDisc
337766 ROCKA 4D JR

Sizes	Contact	Med. stance (cm)
90	60	30
100	67	32
110	75,3	36
120	82,6	42
130	92,0	44
140	101,0	46

FEATURES ROCKA 4D

- 4D compatible
- Rocka shape
- Exchangeable Tip & Tail Protectors
- Easy Rent topsheet
- Poplar wood core
- Easy maintenance die-cut base



RX 4D SPEEDDISC

ARTICLE NUMBER

347103

FEATURES

4D compatible, Reclining highback, Rubber dampened base, Padded highback, Power transmission strap, Dura tech toe strap

SIZES S/M/L



NX 4D SPEEDDISC

ARTICLE NUMBER

347403

FEATURES

4D compatible, AutoOpen Total, Toe & Heel base pads, Padded highback, Toolfree forward lean adjuster, Power transmission strap, Dura tech toe strap, Alu buckles

SIZES S/M/L



P THREE 4D SPEEDDISC

ARTICLE NUMBER

347503

FEATURES

Alu Heelcup, Toe & Heel base pads, Padded highback, 3D comfort strap, Dura tech toe strap, Alu buckles

4D compatible

SIZES S/M/L



P 4D JR SPEEDDISC

ARTICLE NUMBER

347603

FEATURES

4D compatible, JR specific construction, Padded junior highback, Fit ankle strap

SIZES JR



650 4D BOA FOCUS WMN

ARTICLE NUMBER

357055

SIZES 225, 235, 245, 250, 255, 260, 265, 270, 275, 280



650 4D BOA FOCUS

ARTICLE NUMBER

357045

FEATURES

4D compatible, Heavy Profile Rubber outsole, Frequency technology, Full toe and Heel protection, Fully covered BOA cable protection, Pro Fit liner, Bamboo Lining Mesh, Double BOA Lacing

SIZES 225, 235, 245, 250, 255, 260, 265, 270, 275, 280, 285, 290, 295, 300, 305, 315, 325



600 4D

ARTICLE NUMBER

357206 - 600 4D

357246 - 600 4D BOA (+Coiler)

357306 - 600 4D WMN

357346 - 600 4D BOA WMN (+Coiler)



FEATURES

4D compatible, Moonwalker R Pro outsole, Cuff cut construction, Heel frame, Rubber Heelcup, Rubber toecap, Exchangeable rubber tongue guard, Bamboo Lining Mesh BOA H2 coiler lacing

SIZES (MEN)

225, 230, 235, 240, 245, 250, 255, 260, 265, 270, 275, 280, 285, 290, 295, 300, 305, 315, 325

SIZES (WOMEN)

225, 230, 235, 240, 245, 250, 255, 260, 265, 270, 275, 280



500 4D

ARTICLE NUMBER

357403 - 500 4D

357443 - 500 4D BOA (+Coiler)



FEATURES

4D compatible, Explorer outsole, Injected Heel section, Rubber covered laceguides, Rubber toecap

BOA H2 coiler lacing

SIZES

225, 235, 245, 250, 255, 260, 265, 270, 275, 280, 285, 290, 295, 300, 305, 315, 325



400 4D JR

ARTICLE NUMBER

357506 - 400 4D JR

357566 - 400 4D JR BOA

FEATURES

4D compatible, Explorer outsole, Rubber covered laceguides, Rubber toecap, Linerless, Bamboo Lining Mesh

SIZES

185, 195, 205, 225, 235, 245, 250

RACE

- WORLD CUP REBELS I.SL **PAGE 20**
- WORLD CUP REBELS I.SPEED PRO **PAGE 21**
- WORLD CUP REBELS I.SPEED **PAGE 22**
- WORLD CUP REBELS I.RACE **PAGE 22**
- WC REBELS ISLR **PAGE 23**
- WC REBELS IGSR **PAGE 23**
- WC REBELS I.SHAPE PRO **PAGE 23**

PERFORMANCE

- SUPERSHAPE I.SPEED **PAGE 24**
- SUPERSHAPE I.MAGNUM **PAGE 24**
- SUPERSHAPE I.RALLY **PAGE 25**
- SUPERSHAPE I.TITAN **PAGE 25**
- PRESTIGE **PAGE 26**
- PREMIUM **PAGE 27**

ALLRIDE

- MONSTER 108 **PAGE 28**
- MONSTER 98 **PAGE 28**
- MONSTER 88 **PAGE 29**
- MONSTER 83 **PAGE 29**
- POWER INSTINCT TI PRO **PAGE 30**
- RAW INSTINCT TI PRO **PAGE 30**

ALLRIDE

- STRONG INSTINCT TI **PAGE 31**
- SUPREME INSTINCT TI **PAGE 31**
- NATURAL INSTINCT **PAGE 31**

FREESKI

- KORE 117 **PAGE 32**
- KORE 105 **PAGE 33**
- KORE 93 **PAGE 33**
- THE ALPINE WALKER **PAGE 34**
- CADDY **PAGE 35**
- FRAMEWALL **PAGE 35**
- THE SHOW **PAGE 35**

WOMEN

- GREAT JOY **PAGE 36**
- WILD JOY **PAGE 36**
- TOTAL JOY **PAGE 37**
- SUPER JOY **PAGE 37**
- EPIC JOY SLR **PAGE 38**
- ABSOLUT JOY **PAGE 39**
- PURE JOY **PAGE 39**

JUNIOR

- WC IRACE TEAM SW SLR II **PAGE 40**
- SUPERSHAPE SLR II **PAGE 41**
- SUPERSHAPE TEAM SLR II **PAGE 41**
- CADDY JR **PAGE 42**
- RESIDUE SLR II **PAGE 42**
- JOY SLR II **PAGE 43**
- SOUPHEAD SLR II **PAGE 43**
- MONSTER SLR II **PAGE 43**

RACE

- RAPTOR 140S RS **PAGE 60**
- RAPTOR 120S RS **PAGE 60**

PERFORMANCE

- VECTOR EVO 130S **PAGE 64**
- VECTOR EVO 120S **PAGE 64**
- VECTOR EVO 110 **PAGE 64**
- CHALLENGER 130 **PAGE 66**
- CHALLENGER 120 **PAGE 66**
- CHALLENGER 110 **PAGE 67**

ALLRIDE

- HAMMER 110 **PAGE 62**
- THRASHER 100 **PAGE 63**
- THRASHER 80 **PAGE 63**
- ADVANT EDGE 125S **PAGE 67**
- ADVANT EDGE 105 **PAGE 67**
- ADVANT EDGE 95 **PAGE 67**
- ADVANT EDGE 85 **PAGE 68**
- ADVANT EDGE 75 **PAGE 68**

FREESKI

- ADVANT EDGE 85 **PAGE 68**
- ADVANT EDGE 75 **PAGE 68**
- CUBE3 90 **PAGE 71**
- CUBE3 80 **PAGE 71**
- CUBE3 70 **PAGE 71**

WOMEN

- RAPTOR 110S RS W **PAGE 61**
- RAPTOR 90 RS W **PAGE 61**
- RAPTOR 80 W **PAGE 61**
- VECTOR EVO 110S W **PAGE 65**
- VECTOR EVO 90 W **PAGE 65**
- CHALLENGER 100 W **PAGE 66**
- ADVANT EDGE 95 W **PAGE 69**
- ADVANT EDGE 85 W **PAGE 69**
- ADVANT EDGE 75 W **PAGE 69**
- NEXT EDGE 75 W **PAGE 70**

WOMEN

- ADVANT 65 W **PAGE 70**
- CUBE3 80 W **PAGE 72**
- CUBE3 70 W **PAGE 72**
- CUBE3 60 W **PAGE 72**
- DREAM 100 W **PAGE 73**
- DREAM 80 W **PAGE 73**
- RAPTOR 90S RS **PAGE 74**
- RAPTOR 80 RS **PAGE 74**

JUNIOR

- RAPTOR 70 RS **PAGE 75**
- RAPTOR 50 **PAGE 76**
- RAPTOR 40 **PAGE 76**
- RAPTOR CADDY 50 JR **PAGE 77**
- RAPTOR CADDY 40 JR **PAGE 77**
- 23 **PAGE 79**
- 22 **PAGE 79**
- 21 **PAGE 79**

JUNIOR

- RAPTOR 70 RS **PAGE 75**
- RAPTOR 50 **PAGE 76**
- RAPTOR 40 **PAGE 76**
- RAPTOR CADDY 50 JR **PAGE 77**
- RAPTOR CADDY 40 JR **PAGE 77**
- 23 **PAGE 79**
- 22 **PAGE 79**
- 21 **PAGE 79**

RACE

- FREEFLEX EVO 18 X
ART.N°: 100602 BRAKE 85 [A]
- FREEFLEX EVO 16
ART.N°: 100655 BRAKE 85 [A]
- FREEFLEX EVO 14
ART.N°: 100656 BRAKE 85 [D]
- FREEFLEX EVO 11
ART.N°: 100657 BRAKE 85 [D]

ALLRIDE

- PRD 14
ART.N°: 100660 BRAKE 85 [F]
- PRD 12
ART.N°: 100707 BRAKE 85 [F]
ART.N°: 100708 BRAKE 85 [F]
ART.N°: 100709 BRAKE 85 [F]
ART.N°: 100710 BRAKE 85 [F]
- PR 11
ART.N°: 100715 BRAKE 85 [G]
ART.N°: 100716 BRAKE 85 [G]
ART.N°: 100717 BRAKE 85 [G]
ART.N°: 100718 BRAKE 85 [G]
- PRD 12 MBS
ART.N°: 114157 BRAKE 85 [F]
ART.N°: 114158 BRAKE 85 [F]
- PR 11 MBS
ART.N°: 114159 w/o BRAKE 85 [G]
ART.N°: 114160 BRAKE 85 [G]
ART.N°: 114161 BRAKE 85 [G]

FREESKI

- AAAMBITION 12 AT
ART.N°: 111610 w/o BRAKE [C]
- AAAMBITION 10 AT
ART.N°: 111716 w/o BRAKE [C]
- AAAMBITION 12 AT CARBON
ART.N°: 111710 CARBON S BRAKE 85 [C]
ART.N°: 111711 CARBON M BRAKE 85 [C]
ART.N°: 111712 CARBON L BRAKE 85 [C]
- AAADRENALIN 16 AT SHORT
ART.N°: 114105 w/o BRAKE [B]
AAADRENALIN 16 AT LONG
ART.N°: 114106 w/o BRAKE [B]
- AAADRENALIN 13 SHORT
ART.N°: 114010 w/o BRAKE [F]
AAADRENALIN 13 LONG
ART.N°: 114011 w/o BRAKE [F]
- AAATACK² 18 X GW
ART.N°: 114111 w/o BRAKE [A]
- AAATACK² 12 GW
ART.N°: 114135 BRAKE 85 [A]
ART.N°: 114136 BRAKE 95 [A]
ART.N°: 114137 BRAKE 110 [A]
- AAATACK² 16 GW
ART.N°: 114112 w/o BRAKE [A]
ART.N°: 114113 w/o BRAKE [A]
ART.N°: 114114 w/o BRAKE [A]
- AAATACK² 14 AT
ART.N°: 114115 w/o BRAKE [A]
- AAATACK² 13 GW
ART.N°: 114120 BRAKE [A]
ART.N°: 114121 BRAKE 85 [A]
ART.N°: 114122 BRAKE 95 [A]
ART.N°: 114123 BRAKE 110 [A]
ART.N°: 114124 BRAKE [A]
ART.N°: 114125 BRAKE 85 [A]
ART.N°: 114126 BRAKE 95 [A]
ART.N°: 114127 BRAKE 110 [A]
ART.N°: 114128 BRAKE [A]
ART.N°: 114129 BRAKE 85 [A]
ART.N°: 114130 BRAKE 95 [A]
ART.N°: 114131 BRAKE 110 [A]
- AAATACK² 11 GW
ART.N°: 114140 BRAKE [L]
ART.N°: 114141 BRAKE 90 [L]
ART.N°: 114142 BRAKE 100 [L]
ART.N°: 114143 BRAKE [L]
ART.N°: 114144 BRAKE 90 [L]
ART.N°: 114145 BRAKE 100 [L]
ART.N°: 114146 BRAKE [L]
ART.N°: 114147 BRAKE 90 [L]
ART.N°: 114148 BRAKE 100 [L]
- AAATACK² 14 AT
ART.N°: 114115 w/o BRAKE [A]
- AAATACK² 13 GW
ART.N°: 114120 BRAKE [A]
ART.N°: 114121 BRAKE 85 [A]
ART.N°: 114122 BRAKE 95 [A]
ART.N°: 114123 BRAKE 110 [A]
ART.N°: 114124 BRAKE [A]
ART.N°: 114125 BRAKE 85 [A]
ART.N°: 114126 BRAKE 95 [A]
ART.N°: 114127 BRAKE 110 [A]
ART.N°: 114128 BRAKE [A]
ART.N°: 114129 BRAKE 85 [A]
ART.N°: 114130 BRAKE 95 [A]
ART.N°: 114131 BRAKE 110 [A]

JUNIOR

- SLR 7.5 AC (JUNIOR)
ART.N°: 100678 BRAKE 78 [H]
ART.N°: 100679 BRAKE 78 [H]
- SLR 4.5 AC (JUNIOR)
ART.N°: 100682 BRAKE 74 [I]
ART.N°: 100683 BRAKE 74 [I]
- EVO 9 AC (JUNIOR)
ART.N°: 100688 BRAKE 78 [J]
- SX 7.5 AC
ART.N°: 111858 BRAKE 78 [J]
ART.N°: 114180 BRAKE 78 [J]
ART.N°: 114083 BRAKE 90 [J]
- SX 4.5 AC
ART.N°: 111554 BRAKE 74 [K]
ART.N°: 111555 BRAKE 74 [K]
ART.N°: 111557 BRAKE 74 [K]
- JOY 11 SLR
ART.N°: 100690 BRAKE 90 [H]
ART.N°: 100691 BRAKE 78 [H]
ART.N°: 100725 BRAKE 78 [H]
- JOY 9 AC SLR
ART.N°: 100726 BRAKE 85 [H]
ART.N°: 100694 BRAKE 78 [H]
ART.N°: 100695 BRAKE 90 [H]
ART.N°: 100696 BRAKE 78 [H]

WOMEN

- JOY 11 SLR
ART.N°: 100690 BRAKE 90 [H]
ART.N°: 100691 BRAKE 78 [H]
ART.N°: 100725 BRAKE 78 [H]
- JOY 9 AC SLR
ART.N°: 100726 BRAKE 85 [H]
ART.N°: 100694 BRAKE 78 [H]
ART.N°: 100695 BRAKE 90 [H]
ART.N°: 100696 BRAKE 78 [H]

RACE

- STIVOT RACE CARBON
PAGE 106
- STIVOT RACE CHINGUARD
PAGE 106
- STIVOT
PAGE 106
- TEAM SL + CHINGUARD
PAGE 106

T-SERIES

- TUCKER BOA
PAGE 107
- TREX
PAGE 107

VISOR

- KNIGHT PRO
PAGE 108
- KNIGHT
PAGE 108

V-SERIES

- VARIUS
PAGE 109
- VICO
PAGE 109
- VARIUS BOA
PAGE 109

WOMEN

- THEA BOA
PAGE 110
- TINA
PAGE 110
- QUEEN
PAGE 110

WOMEN

- VANDA BOA
PAGE 111
- VANDA
PAGE 111
- VALERY
PAGE 111

JUNIOR

- TAYLOR
PAGE 112
- JOKER
PAGE 112
- STAR
PAGE 112

PERFORMANCE

- FLEXOR VEST
PAGE 132

WOMEN

- FLEXOR VEST WOMAN
PAGE 133

JUNIOR

- FLEXOR JR UNIT RACE
PAGE 133
- FLEXOR JR UNIT
PAGE 133
- FLEXOR JR VEST
PAGE 133

RACE PERFORMANCE

- FLEXOR UNIT RACE
PAGE 132
- FLEXOR UNIT
PAGE 132

RACE

- WORLD CUP SG
PAGE 148
- WORLD CUP SL
PAGE 148

FREESKI

- HEAD KORE 2 PIECE
PAGE 151

WOMEN

- JOY BLACK NEON YELLOW
PAGE 152
- JOY WHITE BLACK
PAGE 152
- JOY
PAGE 152

JUNIOR

- SUPERSHAPE TEAM
PAGE 153
- MONSTER JR.
PAGE 153
- JOY GIRL
PAGE 153

RACE

- REBELS TRAVELBAG
PAGE 140
- REBELS BACKPACK
PAGE 140
- REBELS RACING BACKPACK
PAGE 140
- REBELS DOUBLE SKIBAG
PAGE 141

ALLRIDE

- SINGLE & DOUBLE SKIBAG
PAGE 142
- SKI TRAVELBAG
PAGE 143
- BOOT BACKPACK
PAGE 143
- BOOT BAG
PAGE 143

FREESKI

- FREERIDE SINGLE SKIBAG
PAGE 144
- FREERIDE BOOT BAG
PAGE 144
- FREERIDE BACKPACK
PAGE 145
- TRAVELBAG SM
PAGE 146
- LEARJET
PAGE 146

WOMEN

- WOMAN SINGLE SKIBAG
PAGE 147
- WOMAN BAG
PAGE 147

PERFORMANCE

- CARBON PRESTIGE
PAGE 148
- HEAD AIRFOIL
PAGE 149

ALLRIDE

- MULTI S
PAGE 150
- MULTI
PAGE 150

GLOBE SERIES

- GLOBE TVT
PAGE 120
- GLOBE FMR (SPARELENS)
PAGE 121
- GLOBE FMR
PAGE 121
- GLOBE
PAGE 121

HORIZON SERIES

- HORIZON TVT
PAGE 122
- HORIZON FMR (SPARELENS)
PAGE 123
- HORIZON FMR
PAGE 123
- HORIZON
PAGE 123

GALACTIC SERIES

- GALACTIC TVT
PAGE 124
- GALACTIC FMR (SPARELENS)
PAGE 125
- GALACTIC FMR
PAGE 125
- GALACTIC
PAGE 125

INFINITY SERIES

- INFINITY TVT
PAGE 126
- INFINITY FMR (SPARELENS)
PAGE 127
- INFINITY FMR
PAGE 127
- INFINITY
PAGE 127

SOLAR SERIES

- SOLAR FMR
PAGE 128
- SOLAR
PAGE 128

JUNIOR

- STREAM
PAGE 129
- NINJA
PAGE 129

RACE

- HORIZON RACE
PAGE 119
- INFINITY RACE
PAGE 119

TECHNOLOGY FEATURES SKI

ALLRIDE ROCKER: Rocker that is equally at home on bulletproof snow as it is in powder. This profile uses early rise in the tip with regular camber throughout the rest of the ski. 20% rocker - 80% camber.

DIECUT UHM C BASE: This durable workhorse base material is dedicated to all country skiing. Diecuts are added for flare.

E BASE BLACK: Basic black never goes out of style, and it's always durable. Easy gliding is everyone's friend.

ERA 2.0: ERA 2.0 is the little brother of ERA 3.0 and is everything 3.0 has to offer as far as design, performance and geometry integration, but without the addition of "Rebound" with its piezoelectric Intellifibers.

ERA 3.0: A masterful blend of three independently important technologies to make the ultimate allcountry skis. **ROCKER + RADIUS + REBOUND = ROCKER DONE RIGHT.**

ERA 3.0 S : "Sports version" of ERA 3.0 with a multifaceted ski designed with race innovation and inspiration, yet now with the addition of Rocker, Radius and Rebound. Totally new skiing experience with 10% rocker and 90% camber.

HIGHLY TRANSPARENT UHM BASE: A high-density, determinedly durable base that allows gorgeous graphic details to shine through. The perfect combination of fashion and function.

INTELLIGENCE™ TECHNOLOGY: Piezoelectric fibers that absorb vibrations at the speed of light. As you ski faster, the Intelligence™ stiffens the ski to increase stability. It adapts to where and how you ski.

INTELLIGENCE™ CHIP TECHNOLOGY: With Intelligence™ Chip Technology the electrical energy produced by the Intellifibers is not just recycled but accumulated and released bit by bit through a pre-programmed chip.

ISS - INDEPENDENT SUSPENSION SYSTEM: Elastomeric vibration killers located in the tip, tail and underfoot. The elastomers quiet the vibrations that are commonly associated with rockered skis. Underfoot, the vibrations are dampened to provide the skier with a smooth ride.

JUNIOR POWER FRAME: A geometric ski shape that provides structural strength to the outer edges of the ski through geometric design, as opposed to altering the core material or density of the ski. Also, for kids it looks cool and feels different than a standard flat ski.

KERS: A computerized piezoelectronic device that stores ski energy and releases it at the end of each turn. In reality, it's a turbo charger for your skis.

NANO TECH SURFACE: A permeable nonstick surface with similar molecular compounds and structure to that of a skis base material. This allows you to wax and alter the surface with standard ski wax to assure a lightweight nonstick and snow free surface for your trek up.

PNP ROCKER: Very subtle tip and tail rise with regular camber construction underfoot. PNP Rocker provides a rider a smother turn initiation as well as reduced edge contact to seamlessly butter into tricks and initiate spins. 30% rocker and 70% camber.

POWER SIDEWALL JACKET: An innovation in ski construction that combines the well known fiber jacket construction with ABS sidewalls. A light-weight ski with easy skiing performance including sidewalls for better dampening, shock absorption and edge grip. Performance at its best for its great target group.

RACE STRUCTURED UHM C BASE: The highest quality, fastest base and finish known to man. The technicians who build the skis for our World Cup Rebels use the same material and machines to put this scary fast base and structure into your skis.

RD RACING TOP SHEET: A thinner topsheet material designed to maximize responsiveness. Exclusive to our RD skis.

REBEL CAMBER: Some years ago it was years ago, it was rebellious to have rocker. Now, it's rebellious to have camber. With Rebel Camber, we feature explosive acceleration and excellent edge grip for the World Cup Rebel inside you.

SANDWICH CAP CONSTRUCTION: We take the basic framework from the world cup sandwich and place a cap that just wraps over the top edge of the sidewall to make the ski more suitable for all mountain skiing. Bomber construction with a rounded top edge makes for one incredible allcountry ski.

SANDWICH TWINTIP CONSTRUCTION: We blend a full vertical laminate wood core for durability and add our bomber Independent Suspension System for killing chatter. Pipe, park, big mountains, whatever, bring 'em on and let this construction rip.

STRUCTURED SURFACE: An extra-durable topsheet with a structured exterior. Designed to hold up against the most extreme abuse.

STRUCTURED UHM C BASE: The same high quality material used in HEAD's world-leading race skis is used here. Different structured running base for all conditions.

TNT ROCKER: Tip and tail rocker combined with regular camber underfoot. This combination creates a surfy feel in powder while maintaining hard snow versatility. 40% rocker - 60% camber.

TUFFWALLS: Impact resistant ABS sidewalls. While maintaining responsiveness, Tuffwalls are designed to take a beating

TWINTIP CONSTRUCTION: A vertically laminated wood core, surrounded by a sock of fiberglass and covered by a durable topsheet. This forgiving twin tip construction is slightly softer than our sandwich twin tip layup, making it better for learning pipe and park tricks.

UHM C BASE: Our highly durable base material for getting the job done well. Not flashy, but steady and stable. The kind of base that will last for years.

WOOD CORE CAP CONSTRUCTION: A vertically laminated wood core, surrounded by a sock of fiberglass and covered by a durable topsheet. This forgiving construction is slightly softer than our sandwich cap making it ideal for ramping up the learning curve.

WORLD CUP SANDWICH CONSTRUCTION: The basic construction invented by Howard Head in the 1940's, perfected and hand built by the finest ski technicians in the modern world. The vertical laminate wood core is embraced by speedfreak phenolic sidewalls and the finest Titanal. This is the fastest construction on the planet. Period.

TECHNOLOGY FEATURES BINDINGS

ABS - ANTI BLOCKING SYSTEM: The exclusive TYROLIA technology of the ABS continuous band allows the boot to move out of the binding almost without any friction, hence delivering maximum safety in case of icing up, dirt and boot wear.

RACE TOE: The new construction of the roller pincer system and its wings guarantee utmost stability. The newly designed wings overlap better with the ski boot interface - the innovative concept includes longer wings and is closer to the ski boot. Therefore, the ski boot is stable and attached to the binding with less forward pressure. The synchro adjustment of the wings provides precise adjustment to ski boot sole heights, preventing wobbling between binding and boot.

AFS - ANTI FRICTION SLIDER: New weight optimized adapter for gliding insert at Power Bindings for reduced friction, constant release values and maximum safety.

AFS JUNIOR: The innovative mechanical Anti Friction Slider (AFS) automatically adjusts to the boot sole height, compensating A/C standards as well as height differences due to icing up, dirt or boot wear.

AFS METAL: The 68 mm wide slider plus a stainless steel gliding element provides constant release values and results in a broader contact area to the ski boot sole.

AT TOE: The Alpine Touring (AT) Toe can be easily adjusted to alpine and touring boot norms and it secures constant release values also with rubber soles.

BRAKES: HEAD offers brakes with different width for optimal fit on wider skis and fat skis up to 150 mm ski width in the brake area. Some binding models are delivered without brake – "w/o brake" – to avoid brake exchange later on.

CLIMBING AID: The climbing aid with its different climbing positions, which can be operated without stepping out of the binding, provides excellent balance and effortless climbing.

DURA-COATING: Scratch resistant electrostatic powder coating provides environmentally friendly design, optimal durability and a variety of possible colors and color combinations.

FREEFLEX PRO: Best performance enabled by the innovative Freeflex Pro System. The free-gliding heel allows the ski to bend through unimpeded and to retain its natural dynamics. Due to the reduced stand height, the Freeflex band is now much closer to the ski boot. Constant release values reduce the risk of injury and ensure safe ski steering.

FR PRO TOE: The Freeride (FR) Pro Toe can be easily adjusted to different boot sole heights. Its horizontal spring reflects the modern architecture of the AAA-Series.

FULL DIAGONAL: Intelligent 180° release both horizontally and vertically of the Diagonal Toe and therefore ensures maximum safety in backward twisting-fall situations.

RX-DIAGONAL HEEL: The RX-Diagonal Heel provides maximum safety with a 150° release. Thus, pressure on the knee and ligaments upon twisting forward falls and the risk of injury are reduced.

SUPERLITERAIL SYSTEM: In combination with the integrated Freeflex-Function the SLR Base provides better energy transmission without affecting the natural ski flex. During the turn, this SuperLiteRail Base guarantees constant force distribution which leads to flawless control, thus enhancing the on hill experience. The remarkable benefits include highly efficient and agile ski performance.

RX TOE: The performance oriented RX toe defines stability and power, much as a strong and tough bull would extremely durable and absolutely reliable.

POWERRAIL: The unrivalled technology for retail, demo & rental by the well-received rail system on a modular basis provides easiest handling, maximum flexibility, optimized performance, perfect match, more stability and durability.

RACE DIAGONAL: Diagonal Toe tuned for racing purposes. Due to its higher release force vertically than horizontally, it holds up to the high backward lean forces in racing.

RACE LITE HEEL: The lighter variant of the Race Pro Heel for young up-and-comers and speed stars of tomorrow.

RACE PRO HEEL: The stand height was reduced according to the actual FIS rules. An increased contact area reduces friction and provides constant forward pressure in all skiing situations.

SX LITE HEEL: Weight optimized toe for junior and light-weight skiers with proven safety features of the HEAD/TYROLIA binding technology.

SOLID COLORED: Solid colored plastic parts are not coated with a separate color layer. Instead, the color has been added to the plastic granulate already. Thus, those parts are absolutely scratch resistant and durable but less color options are available.

SLR II BASE: With the 2-piece SLR II base, weight was reduced significantly. The benefits: easier turns, less fatigue and more fun on the slopes! The base offers 3 different mounting positions to cover boot sole lengths between 199 and 347 mm.

SX HEEL: Based on new kinematics the ski boot is precisely secure in the binding. This ensures exact and more direct power transmission from boot to edge.

SX JR. HEEL: The new junior heel with improved kinematics to increase safety and performance for junior skiers.

SX JUNIOR TOE: The innovative kinematics of HEAD's LX and SX adult line provide advantages in performance and stability for the SX Junior line for young speedsters as well.

SX KID HEEL: The SX Kid heel provides the little ones with the best in the latest technologies and safety standards for binding innovation and integrates the new kinematics for the younger set, too. Because safety is paramount, always.

SX KID TOE: With the SX kid toe for up-and-comers and integrated innovative LX/SX kinematics ski steering now requires even less effort.

SX TOE: The kinematic improvements are reflected in the product design of the SX toe as well. With its high cheek bones it reminds of a fox – smart, spry, agile and very clever.

TEFLON WIDE: The wide Teflon® insert ensures better force transmission, more stability and therefore optimal performance.

TELESCOPIC TUBE: With only one binding model it is possible to cover the entire range of different sole lengths (from 260 mm up to 350 mm).

TRP - TYROLIA ROLLER PINCE SYSTEM: The TYROLIA Roller Pincer Toe System (TRP System) of the HEAD bindings with its four rollers and gliding inserts ensure a 180° release and exact centering of the ski boot. The TRP system reduces the load on knees and ligaments and improves performance considerably.

TECHNOLOGY FEATURES BOOTS

LINERS

DOUBLE POWER BOOSTER VELCRO: The strap of the Double Power Booster Velcro works as a double pulley for better closure and a tighter wrapping on the cuff. The elastic Booster strap allows more dynamic response on the boot. The result is more precise transmission and faster ski reaction.

DOUBLE POWER VELCRO STRAP: Developed and patented by HEAD, this velcro strap uses a double-pulley system, which gives 100% more closing power, by reducing the effort needed by 50%. The length of the Double Power Velcro can be customized to "wide" or "narrow" by choosing between the internal or external ring. The result is exceptional support through the shaft of the boot.

HEATFIT (HF) LINERS: Multi-component liners with moldable inserts in liner and tongue. 5 minutes of heating, is all that is required, to make the lining adapting and get the perfect precision and comfort.

QUICK ENTRY LINERS: These liners come with a unique easy entry construction in the fore foot. Developed both for skiing and walking, Quick Entry liners always feel extremely comfortable.

PERFECT FIT (PF): Perfect Fit is the revolutionary customization system that provides the best level of precision, comfort and durability. The Perfect Fit material allows the liner to adapt to your feet, ensuring maximum power transmission. 5 minutes of heating at 80 degrees, is all that is required, to make the lining adapting and get the perfect precision and comfort.

PRO LINERS: Pro Series are thin and very supportive liners developed to assure maximum wrapping and extreme high performance. They come with a stretchy upper material, thermo-moldable ankle inserts and a rear sliding insert.

BUCKLES

DOUBLE POWER LEVER:

The Double Power lever reduces the effort needed to close the buckle by 50%. Developed and patented by HEAD.

DOUBLE POWER SPINEFLEX BUCKLE:

Spineflex buckle featuring Double Power lever.

DOUBLE POWER SPINE-TECH BUCKLE:

Spine-tech buckle featuring Double Power lever.

SPINEFLEX BUCKLE: A revolutionary buckle concept with a flexible element and a constant closure point. The flexible element allows the buckle to adapt to the shell profile. The constant closure point increases the overlap between the shell flaps and reduces pressure points. The increased comfort and precision results in better performance.

SPINE-TECH BUCKLE: The Spine-Tech buckle features a constant traction closure point. This translates into a reduction in pressure points, an increased overlap between shell flaps, more comfort, and more precision.

SUPERMACRO RATCHET:

An adjustable, ratcheted toothplate that provides 28 mm of calf-adjustment.

WIDE-BODY BUCKLE:

Oversize buckle designed for an extreme ease of use. The fastest way to close the boot's cuff.

FEATURES

ADAPTIVE FIT TECHNOLOGY:

HEAD patented mechanism in the sole which allows the user to change the width of the boot from 103 to 101 mm with one turn of a screw.

ADJUSTABLE REAR SPOILER:

Height adjustable spoiler increases rearward support as it's raised.

ADJUSTABLE WEDGE ARCH SUPPORT:

Internal wedge with ON-OFF mechanism customizing the arch of the foot depending on its anatomy.

DOUBLE ADJUSTABLE PROFILE: A double mechanism in the upper rear part of the boot which adapts the circumference of the cuff up to 1 cm to fit individual anatomical needs. Located on the either side of the cuff's spine, this mechanism allows the cuff to adjust up to 1 cm to better fit the anatomical needs of skier.

EASY ENTRY SHELL CONSTRUCTION:

Front plate easy opening construction to let the youngest get in smoothly.

EASY ENTRY SHELL DESIGN: Located in the throat of the boot, 4 channels are cut into the plastic to reduce the thickness of the material and thus provide smoother entry and better wrapping to the foot.

ENERGY FRAME: Specifically designed to reinforce the EDGE line shell structure, the Energy Frame lands more stability and performance to the boot.

TRI(BI)-INJ. FRAME:

A high performance, multi-density shell that optimizes easy entry, foot wrapping, comfort and energy transmission.

FLEX STANCE TUNING: Screw mechanism with a plate support on the spine of the cuff. By adding the screw(s) the link between shell and cuff becomes stronger and the flex of the boot stiffer. It also works as a forward lean adjuster.

FLEX TUNING: A screw mechanism on the spine of the cuff that links shell and cuff. To get a softer flex, the screw(s) can be replaced by the plastic caps included in the box.

INTEGRATED AUTOSKIWALK (ASW): HEAD patented integrated device which automatically switches between skiing and walking position when stepping in or out of the bindings.

POWER CONTROL FRAME:

Designed to reinforce the Cube 3 line shell structure in order to give more stability and performance to the boot

SKI-HIKE SYSTEM:

Is a device which allow the easiest selection of ski and hike mode available. Provides a powerful connection between the cuff and shell for maximum precision and impulse transmission while skiing.

SOFTWALK HEEL + GRIP SYSTEM: HEAD patented cushion positioned in the heel for shock absorption and smoother heel striker, without compromising the performance. The grip system is a rubber insert which provides grip for walking on slippery surfaces.

STIFFER/SOFTER FLEX ADJUSTMENT: It's an adjustment placed on the spine of the cuff to select between a stiffer or softer flex depending on snow condition and level of skiing.

SHOCK ABSORPTION WEDGE:

A rubberized boot board that allows for smoother riding over varied terrain and shock-free landings.

WOMEN SPECIFIC SUPPORTIVE HEEL OPTION:

A heel lift developed exclusively for women to be placed into the boot for optimized heel retention and maximum comfort.

WHAT'S
YOUR
LIMIT?

HEAD UNITS

AUSTRIA

HEAD Austria GmbH
Tyroliaplatz 1
2320 Schwechat
Austria
T. +43 1 701 79 0
E. info@at.head.com

CANADA

HEAD Canada Inc
P.O. Box 3620
Station Main
Guelph, Ontario N1H 7H1
Canada
T. +1 519 822 15 76
E. info@ca.head.com

CZECH REPUBLIC & SLOVAKIA

HEAD International GmbH
T. +420 267 281111
E. infoczechia@head.com

FRANCE

HEAD France
ZA les Condamines
Bresson BP 29
38320 Eybens
France
T. +33 476 62 69 00
E. standard@fr.head.com

GERMANY

HEAD Germany GmbH
Velaskostr. 8
85622 Feldkirchen
Germany
T. +49 89 90 99 95 0
E. info@de.head.com

ITALY

HEAD International
c/o MARES SPA
Salita Bonsen, 4
San Pietro di Novella
16035 Rapallo (GE)
Italy
T. +39 0185 201 1
E. info-head@it.head.com

JAPAN

HEAD JAPAN
3-27 Kanda-Jimbocho
Chiyoda-ku
Tokyo 101-0051
Japan
T. +81 3 3221 7921
E. sales@jp.head.com

BENELUX

HEAD International GmbH
Plesmanstraat 1
3833 LA Leusden
The Netherlands
T. +31 630 22 81 40
E. info.benelux@head.com

POLAND

HEAD International GmbH
Ul. Rydlówka 20
30-363 Kraków
Poland
T. +48 12 255 44 12
E. info@pl.head.com

SPAIN

HEAD SPAIN S.L.
Roger 65-67 5a
08028 Barcelona
Spain
T. +34 93 409 20 80
E. info@es.head.com

SWITZERLAND

HEAD Switzerland AG
Ruessenstrasse 16
6342 Baar
Switzerland
T. +41 41 767 07 07
E. info@ch.head.com

UNITED KINGDOM

HEAD UK Ltd
2 Beezon Road
Kendal, Cumbria
LA9 6BW
UK
T. +44 15 39 72 47 40
E. info@uk.head.com

USA

HEAD USA, Inc.
3125 Sterling Circle
Suite 101
Boulder, CO 80301
USA
T. +1 800 874 3235
E. info@us.head.com

HEAD TRADE

HEAD INTERNATIONAL

HEAD International GmbH
Wuhrkopfweg 1
6921 Kennelbach
Austria
T. +43 55 74 608 0
E. trade@head.com

ARGENTINA

Sports & Adventure S.A.
T. +54 11 6320 3400
E. administracionventas@grupovieytes.com

AUSTRALIA

Rosbert International
T. +61 3 909 577 11
E. rosbert@rosbert.com.au

BULGARIA

Miras-Krastevi LTD
T. +359 2 962 72 01
E. office@miras-sport.com

CHILE

Inver Tech Ltda
T. +56 2 681 23 08
E. pablo.zuninoerlaver@gmail.com

CHINA

B.C. SPORTS
T. +86 (25) 86 999 779
E. wuyj@bc-sports.com.cn

CROATIA

Zurcom d.o.o.
T. +385 (0)1 455 69 79
E. info@zurcom.hr

DENMARK

Cool Sport AIS
T. +45 8853 7777
E. ck@cool sport.dk

ESTONIA

Sportland
International Group
T. +372 (654) 8400

FINLAND

Oy Anglo-Nordic AB
T. +358 9 4153 5300
E. myynti@anglo.fi

GREECE

Parnass Ski
T. +30 2670 22646
E. parnas-ski@otenet.gr

HUNGARY

WINTERSPORT Co. Ltd.
T. +36 70 376 0640
E. wintersport@wintersport.hu

ICELAND

Utivera EHF T/A Everest
T. +354 533 44 50
E. everest@everest.is

IRAN

Speed Jam Parseh Co. Ltd
T.: +982166965702
E. info@headiran.ir

KAZAKHSTAN

Intelli Sport
T. +7 333 21 777 08
E. intelli.sports@gmail.com

LATVIA

CB Profils, Ltd.
T. +371 67317780
info@burusports.lv

LEBANON

Mike Sport
T. +961 1 8888 55
E. mispo@mikesport.com

MACEDONIA

Vekon Int Dooel
T. +389 23 298 259
E. borace@elteh.com.mk

NEW ZEALAND

Allsports Distribution Ltd
T. +64 7 377 1033
E. info@allsports.co.nz

NORWAY

Gresvig AS
T. +47 23 35 85 00
E. christopher.rogge@gresvig.no

ROMANIA

RIDESPORT S.R.L.
T. +40 729 622 060
E. office@ridesport.ro

RUSSIA

Girvas Sport
T. +7 499 171 44 65
E. m.teplov@girvas.ru

SERBIA

Markoni Sport .d.o.o.
+381(0) 328 58 97
E. veleprodaja@markonisport.rs

SOUTH KOREA

Alchemist
T. +82 02 430 8060
E. alchemist.kr@gmail.com

SWEDEN

Interski AB
T. +46 647 5 06 10
E. info@interski.se

TURKEY

Sportive Sport
T. +90 850 221 23 00
E. onurbilici@sportive.com.tr

UKRAINE

Extreme Style
T. +380 97 511 6510
E. denis@eltrade.com.ua

